

---

# MANUAL

---

---

**1223/33**

**1225/35**

**1227/37**

**MultiMode™  
MOTOR CONTROLLERS**

---

© 2011 CURTIS INSTRUMENTS, INC.

1223/33, 1225/35, 1227/37 Manual  
p/n 16879, Rev. D: May 2011



**CURTIS INSTRUMENTS, INC.**

200 Kisco Avenue  
Mt. Kisco, New York 10549 USA  
Tel. 914.666.2971  
Fax 914.666.2188

[www.curtisinstruments.com](http://www.curtisinstruments.com)



# CONTENTS

1. OVERVIEW.....	1
2. INSTALLATION AND WIRING.....	5
1223/33 Controllers .....	6
1225/35 Controllers .....	10
1227/37 Controllers .....	14
Throttle Wiring.....	18
5k $\Omega$ , 3-wire potentiometer throttle .....	18
0–5V throttle.....	19
Curtis ET-1XX electronic throttle .....	20
Speed limit pot.....	21
Auxiliary Driver Output Options .....	23
Program 1.....	23
Program 2.....	23
Emergency reverse (belly button) wiring check....	23
Switches and Other Hardware .....	24
Control switches.....	24
Keyswitch and power enable switch.....	24
Push switch .....	24
Brake release switch .....	25
Inhibit .....	25
Panel indicator LEDs.....	25
Horn .....	26
Main contactor.....	26
Circuitry protection devices.....	26
3. PROGRAMMABLE PARAMETERS .....	27
Acceleration Rate, M1/M2 .....	29
Deceleration Rate, M1/M2.....	29
Reverse Deceleration Rate, M1/M2.....	29
Maximum Speed, M1/M2.....	30
Minimum Speed, M1/M2 .....	30
Reverse Speed .....	31
Creep Speed.....	32
Emergency Reverse Speed.....	32
Throttle Input Type.....	33
Direction Input Type.....	34

=====	Throttle Autocalibration .....	35
=====	Throttle Deadband .....	36
=====	Throttle Gain .....	37
=====	Ramp Shape (Static Throttle Map) .....	38
=====	Main Current Limit, M1/M2 .....	40
=====	Emergency Reverse Current Limit .....	40
=====	Calibration 5: Regen Current Boost .....	40
=====	Program 1 Auxiliary Driver.....	41
=====	Program 2 Auxiliary Driver.....	42
=====	Program 4: Brake Holding Voltage .....	43
=====	High Pedal Disable (HPD) .....	43
=====	Static Return to Off (SRO).....	43
=====	IR Speed Coefficient, M1/M2 .....	44
=====	Calibration 4: IR Stiffness.....	44
=====	<b>4. OEM-SPECIFIED, FACTORY-SET PARAMETERS .....</b>	<b>45</b>
=====	Speed Interlocks.....	45
=====	Speed Limit Pot Fault .....	45
=====	Main Contactor Fault Check.....	46
=====	Overvoltage .....	46
=====	Emergency Reverse Check .....	46
=====	Switch Type .....	47
=====	Input Polarities .....	47
=====	Emergency Reverse .....	47
=====	Key Off Deceleration.....	48
=====	Power Saver .....	48
=====	MultiMode™ .....	48
=====	<b>5. INSTALLATION CHECKOUT .....</b>	<b>49</b>
=====	<b>6. PROGRAMMER OPERATION .....</b>	<b>52</b>
=====	<b>7. DIAGNOSTICS AND TROUBLESHOOTING .....</b>	<b>62</b>
=====	<b>8. MAINTENANCE.....</b>	<b>66</b>
=====	<b>APPENDIX A</b> Glossary of Features and Functions	
=====	<b>APPENDIX B</b> Throttle Mounting Dimensions	
=====	<b>APPENDIX C</b> Curtis WEEE & RoHS Statement	
=====	<b>APPENDIX D</b> Programming Devices	
=====	<b>APPENDIX E</b> Specifications	

---

**FIGURES**

FIG. 1:	Curtis 1221, 1225, and 1227 electronic motor controllers, with handheld 1307 programmer .....	1
FIG. 2:	Mounting dimensions, Curtis 1223/33 controllers .....	6
FIG. 3:	Basic wiring configuration with on/off switches, 1223/33 controllers.....	8
FIG. 4:	Basic wiring configuration with momentary switches, 1223/33 controllers.....	9
FIG. 5:	Mounting dimensions, Curtis 1225/35 controllers .....	10
FIG. 6:	Basic wiring configuration with on/off switches, 1225/35 controllers.....	12
FIG. 7:	Basic wiring configuration with momentary switches, 1225/35 controllers.....	13
FIG. 8:	Mounting dimensions, Curtis 1227/37 controllers .....	14
FIG. 9:	Basic wiring configuration with on/off switches, 1227/37 controllers.....	16
FIG. 10:	Basic wiring configuration with momentary switches, 1227/37 controllers.....	17
FIG. 11:	Wiring for 0–5V throttle .....	19
FIG. 12:	Wiring for Curtis ET-XXX electronic throttle .....	20
FIG. 13:	Effect of speed limit pot position on speed curves .....	21
FIG. 14:	Wiring of speed limit input to enable maximum speed when no speed limit pot is used .....	22
FIG. 15:	Wiring to check the emergency reverse input wiring (belly button check) .....	23
FIG. 16:	Wiring to inhibit operation during battery charging .....	25

FIG. 17: Examples of speed curves with the speed limit pot in its maximum speed position ..... 30

FIG. 18: Examples of speed curves with the speed limit pot in its minimum speed position ..... 31

FIG. 19: Example of reverse speed curve ..... 32

FIG. 20: Effect of adjusting the neutral deadband parameter ..... 36

FIG. 21: Effect of adjusting the throttle gain parameter ..... 37

FIG. 22: Ramp shape (throttle map) for controller with maximum speed set at 100% and creep speed set at 0 ..... 38

FIG. 23: Ramp shape (throttle map) for controller with maximum speed set at 100% and creep speed set at 10% ..... 39

FIG. 24: Ramp shape (throttle map) for controller with maximum speed set at 60% and creep speed set at 10% ..... 39

FIG. 25: Bench test setup for verifying and adjusting the controller's parameters ..... 51

FIG. B-1: Mounting dimensions, Curtis standard 5k $\Omega$ , 3-wire throttle pot ..... B-1

FIG. B-2: Mounting dimensions, Curtis potboxes ..... B-1

FIG. B-3: Mounting dimensions, Curtis footpedal ..... B-2

FIG. B-4: Mounting dimensions, Curtis electronic throttle ..... B-2

---

**TABLES**

TABLE 1: Model comparison chart .....	4
TABLE 2: Throttle styles .....	19
TABLE 3: Resistors for indicator LEDs .....	26
TABLE 4: Programmable throttle input signal types.....	33
TABLE 5: Programmable direction input types.....	34
TABLE 6: Configuration options: Program 1 Driver .....	41
TABLE 7: Configuration options: Program 2 Driver .....	42
TABLE 8: Troubleshooting chart .....	63
TABLE 9: Status LED fault codes .....	64
TABLE D-1: Specifications, 1223/33 controllers .....	D-1
TABLE D-2: Specifications, 1225/35 controllers .....	D-2
TABLE D-3: Specifications, 1227/37 controllers .....	D-3





## 1

## OVERVIEW

Curtis 1223/33, 1225/35, and 1227/37 MultiMode™ controllers are programmable permanent magnet motor speed controllers designed for use in a variety of small electric vehicles. These controllers extend the capabilities of the 1208, 1203A, and 1213 families for applications where greater functionality or programmability is desired.

The series includes Models 1223/33 (card only, 24–36V), Models 1225/35 (sealed case, 24–36V), and Models 1227/37 (ABS cover, 24–48V).

The 122X models (1223/25/27) are designed primarily for use in mobility aids, scooters, and other small personnel carrier applications. The 123X models (1233/35/37) offer additional features for industrial applications and are typically used in scrubbers, AGVs, small walkies, etc.

**Fig. 1** Curtis 1223, 1225, and 1227 MultiMode™ electronic motor controllers, with 1307 handheld programmer.

*The corresponding 123X models (1233, 1235, and 1237) are externally identical to the 122X models but have additional built-in features.*



The 1223/33, 1225/35, and 1227/37 MultiMode™ controllers offer smooth, silent, cost effective control of motor speed and torque. A four quadrant, full bridge power output stage provides for solid state motor reversing and full braking power without additional relays or contactors.

These controllers are fully programmable by means of the optional handheld 1307 programmer. Use of the programmer offers diagnostic and test capability as well as configuration flexibility.

Like all Curtis motor controllers, this family offers superior operator control of the vehicle's motor drive speed. **Features include:**

- ✓ Full bridge power MOSFET design, providing
  - infinitely variable forward, reverse, drive, and brake control
  - silent high frequency operation
  - high efficiency
- ✓ Programmability through the 1307 handheld programmer
- ✓ Complete diagnostics through the 1307 programmer and Status LED
- ✓ Full compliance with all applicable international standards and TÜV requirements
- ✓ Available for single-ended or wigwag 5k $\Omega$  potentiometer throttles and 0–5V throttles (both standard full stroke and restricted range)
- ✓ MultiMode™ input selects between two different operating modes, thus allowing optimization of vehicle characteristics for different driving conditions (for example, indoor/outdoor)
- ✓ Speed limit input provides linear variable speed limiting with an external pot
- ✓ Improved linear acceleration and deceleration with softened response for smooth operation
- ✓ Current limiting in both driving and regenerative braking modes; increased regen braking current limit available for applications requiring enhanced braking
- ✓ Load compensation stabilizes speed on ramps and over obstacles
- ✓ High pedal disable (HPD) function monitors status of the throttle during turn on and prevents operation until the throttle has been returned to neutral
- ✓ Key off decel function provides a controlled deceleration if the keyswitch is turned off while driving
- ✓ Comprehensive fault detect monitors main contactor, output stage, throttle demand vs. output, etc., and disables the drive functions if any conditions are outside specified limits
- ✓ ISO 7176 compliant throttle fault detection circuitry shuts off controller if throttle pot signal goes out of range for any reason
- ✓ Optional missing brake detector forces neutral in the event of an open brake circuit
- ✓ Anti-rollback/anti-roll-forward circuitry sets brake delay according to speed and direction for improved braking response and minimized rollback on hills, etc.

- ✓ Current limited brake driver protects the controller from shorts in the brake or its wiring; this low side output driver can also be programmed to enable a side broom or brush contactor, hour meter, etc.
- ✓ Brake PWM allows the brake driver to be programmed to a reduced holding voltage
- ✓ Reverse output drives a piezo beeper (customer-supplied) in reverse
- ✓ “Push” input electrically releases brake for key-on pushing (requires that the vehicle be stopped first)
- ✓ “Push-Too-Fast” feature guards against unpowered vehicle runaway by powering up and shorting the motor to limit the speed of the vehicle
- ✓ Inhibit input disables the controller and puts the vehicle in a safe state during charging, etc.
- ✓ Power saver deactivates the main relay after 25 seconds and the entire controller after 25 minutes of non-operation
- ✓ Undervoltage cutback function protects against operation at low battery voltage
- ✓ Overvoltage shutdown function disables the controller and protects against failure due to excessive battery voltages
- ✓ Thermally protected and compensated for stable output and overtemperature protection
- ✓ Reverse polarity protected (battery input)
- ✓ Momentary switch input option with integral LED drivers allows use of membrane power enable, direction, and mode switches
- ✓ SRO input sequencing options *[123X models only]*
- ✓ Emergency reverse (belly button) input causes rapid transition to reverse *[123X models only]*
- ✓ Programmable high side driver output for brake light, belly button check, hour meter, brush contactor, etc. *[123X models only]*

The features of this family of microprocessor-based programmable controllers are summarized and compared to those of the 1208, 1203A, and 1213 controllers in Table 1.

Familiarity with your Curtis controller will help you install and operate it properly. We encourage you to read this manual carefully. If you have questions, please contact the Curtis office nearest you.

**Table 1 MODEL COMPARISON CHART**

	Analog Models			MultiMode™ Microprocessor-Based Models		
	1208	1203A	1213	1223/33	1225/35	1227/37
Voltage Range (V)	12–36	12–36	24–48	24–36	24–36	24–48
Current Range (A) <sup>1</sup>	45–55	60–90	100–200	70–110	90–125	100–200
Current Limited	✓	✓	✓	✓	✓	✓
Regen. Current Limit	—	✓	✓	✓	✓	✓
Undervoltage Protection	✓	✓	✓	✓	✓	✓
Overvoltage Protection	✓	✓	✓	✓	✓	✓
Pot Adjustable	—	✓	✓	—	—	—
Programmable	—	—	—	✓	✓	✓
Diagnostics	—	—	—	✓	✓	✓
Full Bridge	—	—	✓	✓	✓	✓
Wigwag Throttle	✓	✓	✓	✓	✓	✓
Single-Ended Throttle	—	✓	✓	✓	✓	✓
HPD	—	✓	✓	✓	✓	✓
Anti-Rollback	—	—	✓	✓	✓	✓
Anti-Roll-Forward	—	—	✓	✓	✓	✓
Load Compensation	—	—	✓	✓	✓	✓
MultiMode™ Input	—	—	—	✓	✓	✓
Push Too Fast	—	—	✓	✓	✓	✓
Push Input	—	—	—	✓	✓	✓
Key Off Deceleration	—	—	—	✓	✓	✓
Brake Output	✓	✓	✓	✓ <sup>2</sup>	✓ <sup>2</sup>	✓ <sup>2</sup>
Inhibit Input	✓	✓	✓	✓	✓	✓
Reverse Beeper	—	—	—	✓	✓	✓
Power Saver	—	—	—	✓	✓	✓
Speed Limit Input	—	—	—	✓	✓	✓
Momentary Input Option	—	—	—	✓	✓	✓
Output Fault Detect	—	—	—	✓	✓	✓
Open Pot Fault	✓	✓	✓	✓	✓	✓
ISO Pot Fault	—	—	✓	✓	✓	✓
Temperature Compensation	—	—	✓	✓	✓	✓
Temperature Protection	—	✓	✓	✓	✓	✓
SRO	—	—	—	✓ <sup>3</sup>	✓ <sup>3</sup>	✓ <sup>3</sup>
Brake Light Driver (BLD)	—	—	✓	—	—	—
Programmable BLD	—	—	—	✓ <sup>3</sup>	✓ <sup>3</sup>	✓ <sup>3</sup>
Belly Button	—	—	—	✓ <sup>3</sup>	✓ <sup>3</sup>	✓ <sup>3</sup>
BB Check Circuit	—	—	—	✓ <sup>3</sup>	✓ <sup>3</sup>	✓ <sup>3</sup>
Microprocessor	—	—	—	✓	✓	✓
Package Type	Card	Card	ABS cover	Card	Sealed	ABS cover

<sup>1</sup> current depends on voltage and model; maximum listed<sup>2</sup> brake output is programmable<sup>3</sup> 123X series only

# 2

## INSTALLATION AND WIRING

Installation and wiring instructions are presented separately for the 1223/33 controllers, 1225/35 controllers, and 1227/37 controllers. The three individual installation and wiring sections are followed by common sections that cover throttle wiring, auxiliary driver output options, and switches and other hardware.



**Working on electric vehicles is potentially dangerous.** You should protect yourself against runaways, high current arcs, and outgassing from lead acid batteries:

**RUNAWAYS** — Some conditions could cause the vehicle to run out of control. Disconnect the motor or jack up the vehicle and get the drive wheels off the ground before attempting any work on the motor control circuitry. **NOTE:** If the wrong combination of throttle and switch styles is selected with the handheld programmer, the vehicle may suddenly begin to move.

**HIGH CURRENT ARCS** — Electric vehicle batteries can supply very high power, and arcs can occur if they are short circuited. Always open the battery circuit before working on the motor control circuit. Wear safety glasses, and use properly insulated tools to prevent shorts.

**LEAD ACID BATTERIES** — Charging or discharging generates hydrogen gas, which can build up in and around the batteries. Follow the battery manufacturer's safety recommendations. Wear safety glasses.

## 1223/33 CONTROLLERS

### 1223/33 Installation

The controller can be oriented in any position, but the location should be carefully chosen to keep the controller clean and dry. If a clean, dry mounting location cannot be found, a cover must be used to shield the controller from water and contaminants.

The outline and mounting hole dimensions for the 1223/33 controllers are shown in Figure 2. The controller can be mounted by the top of the heatsink or by means of the four mounting holes at the corners of the circuit board.

**Fig. 2** Mounting dimensions, Curtis 1223/33 controllers.

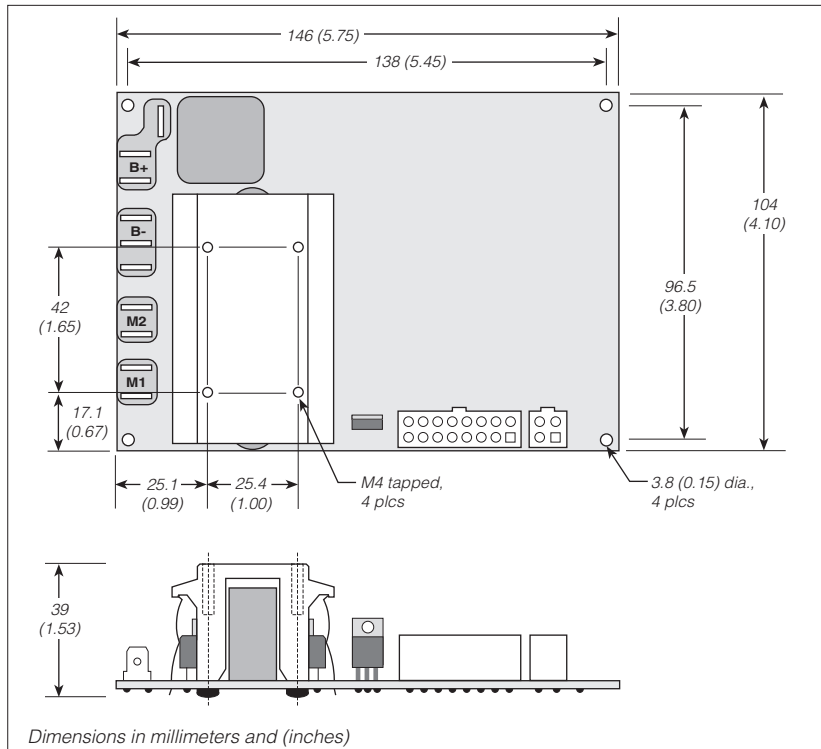

Mounting the controller via the tapped holes in the heatsink is the preferred method and requires M4 screws. If the controller is mounted via the circuit board, care should be taken to ensure that no conductive hardware overlaps the copper planes at the power connect end of the board. Additionally, at least 6 mm (1/4") clearance should be provided below the bottom of the circuit board to prevent shorts to any of the thru-hole connections.

In either case the heatsink should be attached to at least a 100 × 125 × 3 mm (4" × 5" × 1/8") aluminum plate or its equivalent to obtain the rated cur-

rents. Although not usually necessary, a thermal joint compound can be used to improve heat conduction from the heatsink to the mounting surface.

### 1223/33 Low Current Connections

A 16-pin low current connector provides the low current logic control connections. The mating connector is a 16-pin Molex Mini-Fit Jr. connector part number 39-01-2165 using type 5556 terminals.

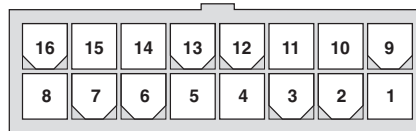

<b>Pin 1</b>	pot high
<b>Pin 2</b>	pot wiper
<b>Pin 3</b>	pot low
<b>Pin 4</b>	speed limit pot wiper
<b>Pin 5</b>	push
<b>Pin 6</b>	inhibit
<b>Pin 7</b>	program 1 driver
<b>Pin 8</b>	brake +
<b>Pin 9</b>	horn driver
<b>Pin 10</b>	emergency reverse ( <i>1233 only</i> )
<b>Pin 11</b>	mode select switch and LED driver
<b>Pin 12</b>	forward switch
<b>Pin 13</b>	direction/reverse switch and LED driver
<b>Pin 14</b>	power enable switch and Status LED driver
<b>Pin 15</b>	keyswitch input (KSI)
<b>Pin 16</b>	program 2 driver ( <i>1233 only</i> )

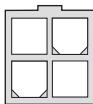

A 4-pin low power connector is provided for the handheld 1307 programmer. The mating cable can be ordered as a separate part: Curtis p/n 16185.

### 1223/33 High Current Connections

Ten 1/4" quick-connect terminals are provided for the high current connections. Three terminals each are provided for the battery **B+** and **B-** connections. The motor connections (**M1**, **M2**) have two terminals each.



### 1223/33 Wiring Configurations

The 1223/33 controller can be configured to work with either on/off or momentary switches for selecting direction and mode. If a power enable switch is used, it must be momentary style. For more information on control switches, see p. 24.

#### With on/off switches

Typical wiring for the 1223/33 controller with on/off switches is presented in Figure 3. This diagram shows the controller configured with the program 1 driver as an electromagnetic brake, the program 2 driver as a brake light driver, and two SPST switches used for selecting direction. NOTE: In the configuration shown, the power enable pin is an output that drives the Status LED. With on/off switches, the power enable function is performed by the keyswitch and a power enable switch is not used.

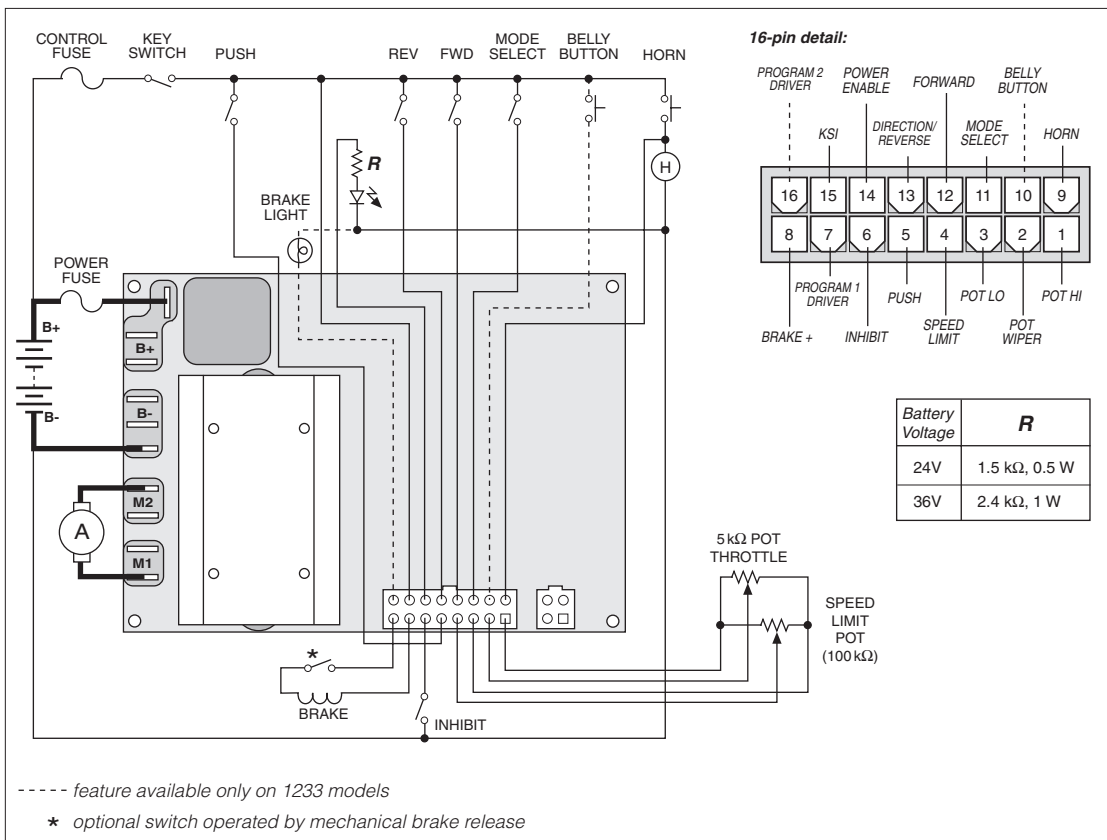
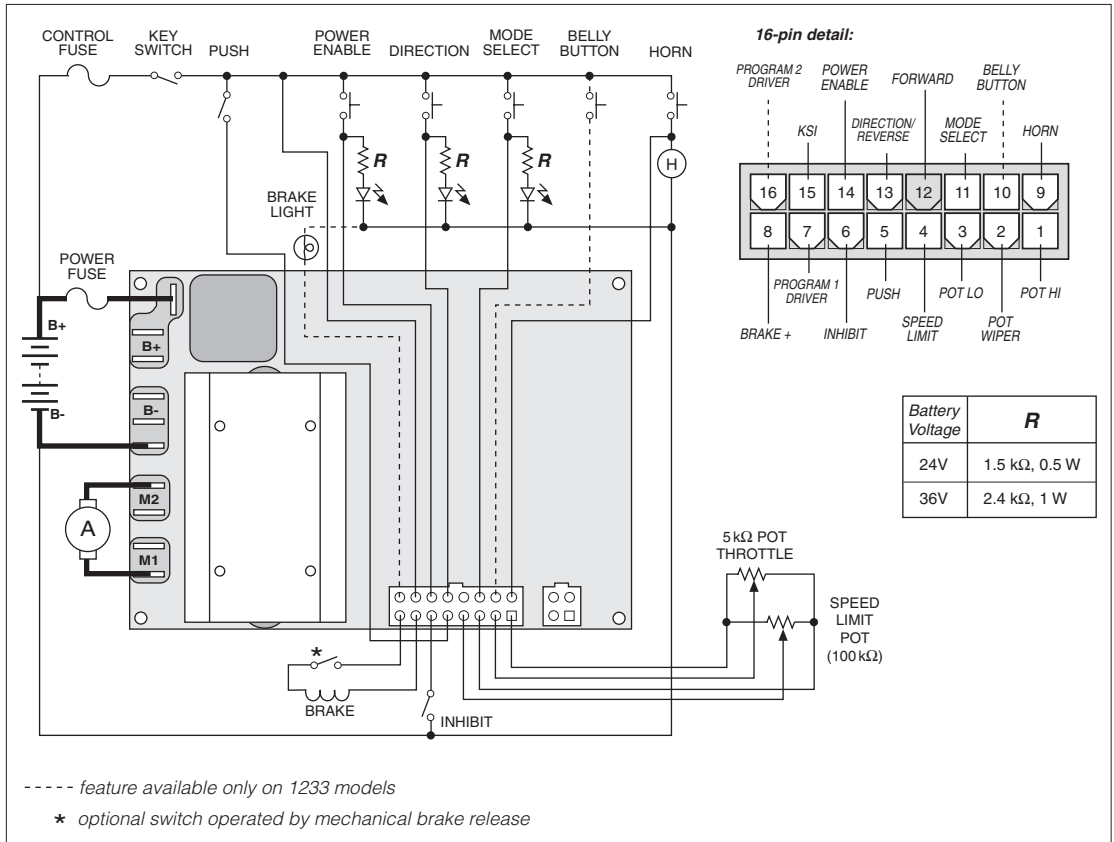

Fig. 3 Basic wiring configuration using on/off switches, Curtis 1223/33 controller.



*With momentary switches*

Typical wiring for the 1223/33 controller with momentary switches is presented in Figure 4. This diagram shows the controller configured with the program 1 driver as an electromagnetic brake, the program 2 driver as a brake light driver, and a single direction switch. NOTE: When a momentary switch is used for the mode input, the controller will always power up in Mode 1 (the default mode).



**Fig. 4** Basic wiring configuration using momentary switches, Curtis 1223/33 controller.

## 1225/35 CONTROLLERS

### 1225/35 Installation

The outline and mounting hole dimensions for the 1225/35 controllers are shown in Figure 5.

**Fig. 5** *Mounting dimensions, Curtis 1225/35 controllers.*

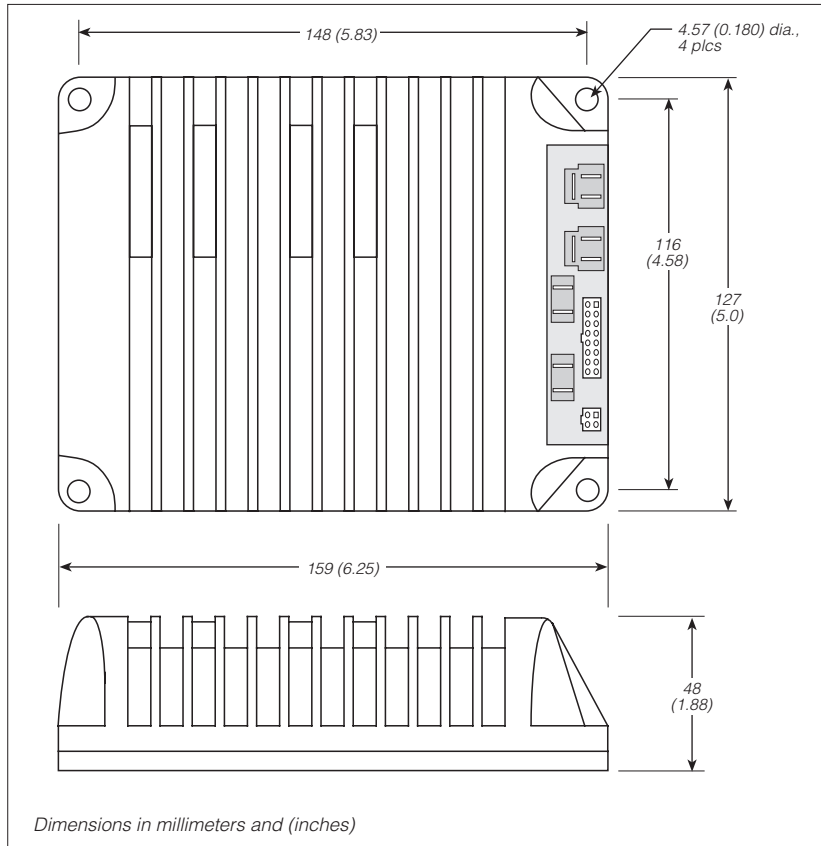

The 1225/35 controller can be oriented in any position. To ensure full rated output power, the controller should be positioned so that the maximum available airflow travels across its ribs. Fasten the controller to a secure mounting bracket or other surface, using the four mounting holes provided. Be sure to allow easy access to the controller's connection face so that the 1307 handheld programmer can be plugged into the controller after it is installed.

The 1225/35 case is designed to meet the IP54 seal requirements for environmental protection against dust and water splash. However, it is nevertheless recommended that the controller be mounted in a clean and dry location.

### 1225/35 Low Current Connections

A 16-pin low current connector provides the low current logic control connections. The mating connector is a 16-pin Molex Mini-Fit Jr. connector part number 39-01-2165 using type 5556 terminals.

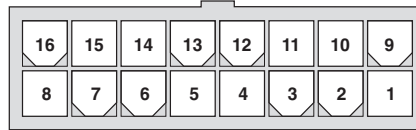

<b>Pin 1</b>	pot high
<b>Pin 2</b>	pot wiper
<b>Pin 3</b>	pot low
<b>Pin 4</b>	speed limit pot wiper
<b>Pin 5</b>	push
<b>Pin 6</b>	inhibit
<b>Pin 7</b>	program 1 driver
<b>Pin 8</b>	brake +
<b>Pin 9</b>	horn driver
<b>Pin 10</b>	emergency reverse ( <i>1235 only</i> )
<b>Pin 11</b>	mode select switch and LED driver
<b>Pin 12</b>	forward switch
<b>Pin 13</b>	direction/reverse switch and LED driver
<b>Pin 14</b>	power enable switch and Status LED driver
<b>Pin 15</b>	keyswitch input (KSI)
<b>Pin 16</b>	program 2 driver ( <i>1235 only</i> )

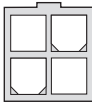

A 4-pin low power connector is provided for the handheld 1307 programmer. The mating cable can be ordered as a separate part: Curtis p/n 16185.

### 1225/35 High Current Connections

Ten 1/4" quick-connect terminals are provided for the high current connections. Three terminals each are provided for the battery **B+** and **B-** connections. The motor connections (**M1**, **M2**) have two terminals each.

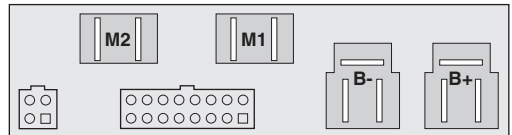

Mating connectors are available. The 3-terminal battery connectors are Curtis p/n 16551, and the 2-terminal motor connectors are p/n 16552. Both connectors use Curtis p/n 16553 terminal pins designed for use with #10 AWG (2.59 mm).

### 1225/35 Wiring Configurations

The 1225/35 controller can be configured to work with either on/off or momentary switches for selecting direction and mode. If a power enable switch is used, it must be momentary style. For more information on control switches, see p. 24.

#### With on/off switches

Typical wiring for the 1225/35 controller with on/off switches is presented in Figure 6. This diagram shows the controller configured with the program 1 driver as an electromagnetic brake, the program 2 driver as a brake light driver, and two SPST switches used for selecting direction. NOTE: In the configuration shown, the power enable pin is an output that drives the Status LED. With on/off switches, the power enable function is performed by the keyswitch and a power enable switch is not used.

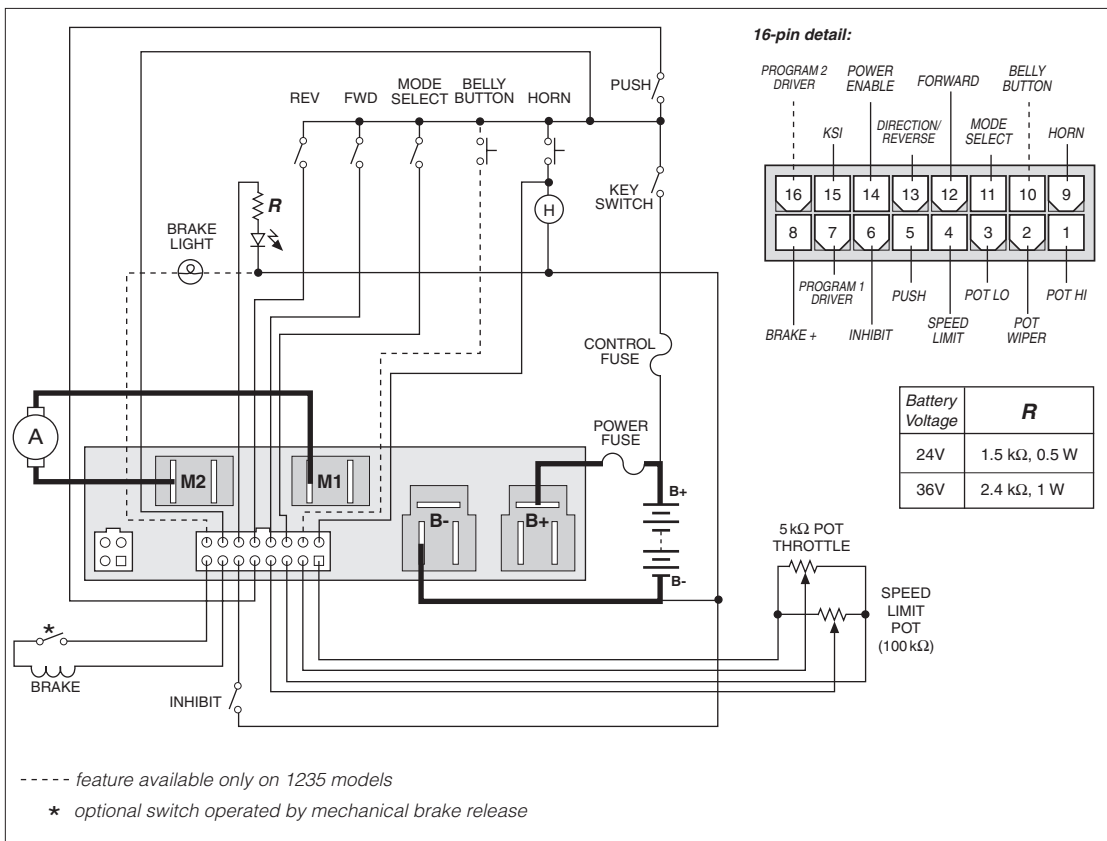
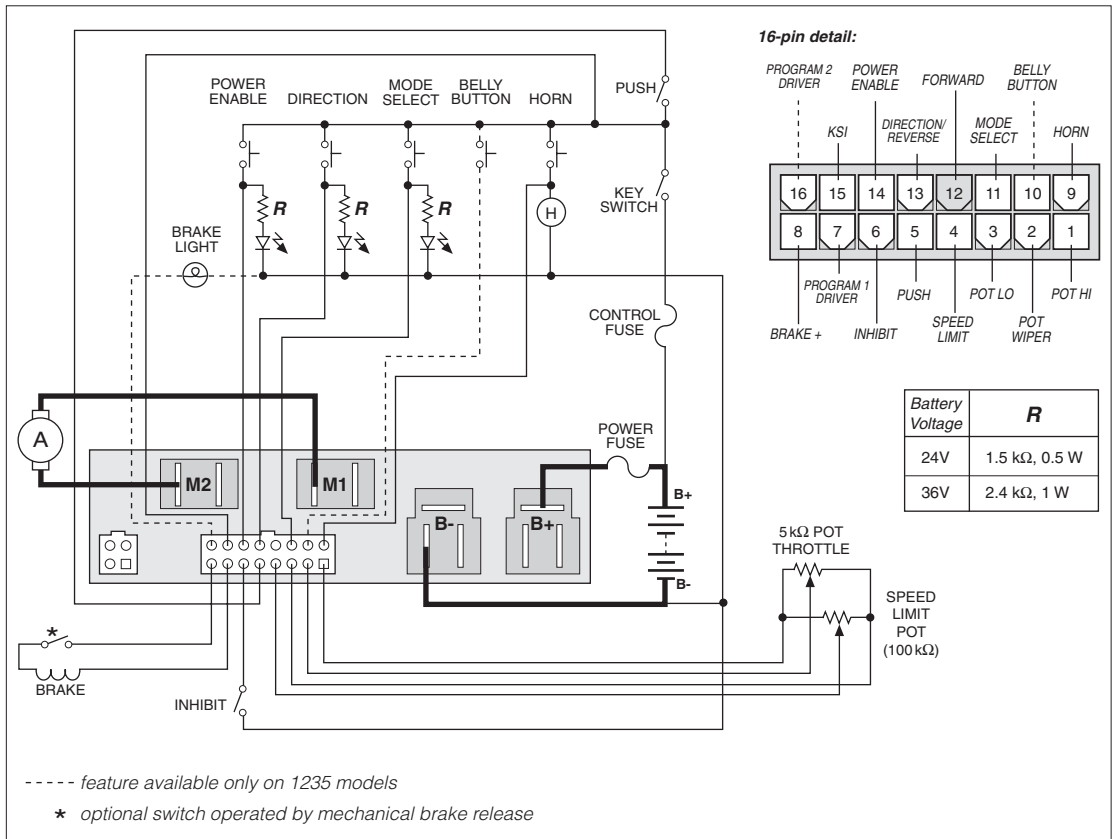

Fig. 6 Basic wiring configuration using on/off switches, Curtis 1225/35 controller.

*With momentary switches*

Typical wiring for the 1225/35 controller with momentary switches is presented in Figure 7. This diagram shows the controller configured with the program 1 driver as an electromagnetic brake, the program 2 driver as a brake light driver, and a single direction switch. NOTE: When a momentary switch is used for the mode input, the controller will always power up in Mode 1 (the default mode).



**Fig. 7** Basic wiring configuration using momentary switches, Curtis 1225/35 controller.

## 1227/37 CONTROLLERS

### 1227/37 Installation

The 1227/37 controller can be mounted in any position, but **the location should be carefully chosen to keep the controller clean and dry. If a clean, dry mounting location cannot be found, a cover must be used to shield the controller from water and contaminants.**

The outline and mounting hole dimensions for the 1227/37 controllers are shown in Figure 8. To ensure full rated output power, the controller should be fastened to a clean, flat metal surface with three screws.

Although not usually necessary, a thermal joint compound can be used to improve heat conduction from the case to the mounting surface.

**Fig. 8** *Mounting dimensions, Curtis 1227/37 controllers.*

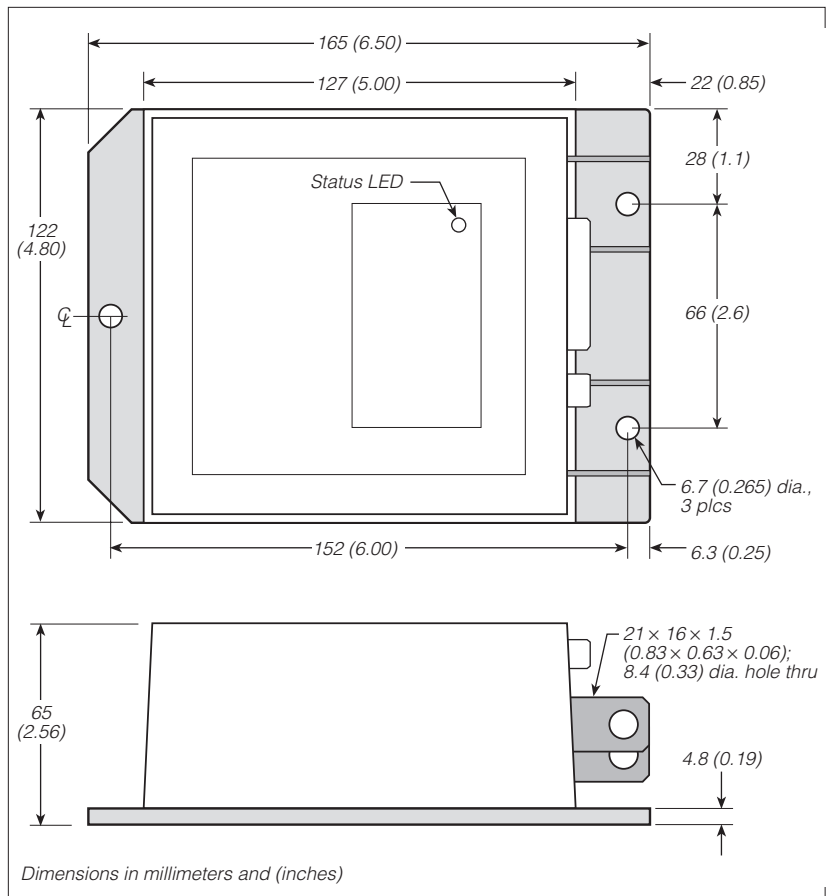

### 1227/37 Low Current Connections

A 16-pin low current connector provides the low current logic control connections. The mating connector is a 16-pin Molex Mini-Fit Jr. connector part number 39-01-2165 using type 5556 terminals.

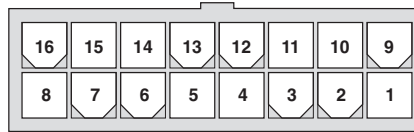

<b>Pin 1</b>	pot high
<b>Pin 2</b>	pot wiper
<b>Pin 3</b>	pot low
<b>Pin 4</b>	speed limit pot wiper
<b>Pin 5</b>	push
<b>Pin 6</b>	inhibit
<b>Pin 7</b>	program 1 driver
<b>Pin 8</b>	main contactor coil driver
<b>Pin 9</b>	horn driver
<b>Pin 10</b>	emergency reverse ( <i>1237 only</i> )
<b>Pin 11</b>	mode select switch and LED driver
<b>Pin 12</b>	forward switch
<b>Pin 13</b>	direction/reverse switch and LED driver
<b>Pin 14</b>	power enable switch and Status LED driver
<b>Pin 15</b>	keyswitch input (KSI)
<b>Pin 16</b>	program 2 driver ( <i>1237 only</i> )

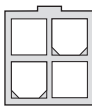

A 4-pin low power connector is provided for the handheld 1307 programmer. The mating cable can be ordered as a separate part: Curtis p/n 16185.

### 1227/37 High Current Connections

Four tin-plated copper bus bars are provided for the high current connections to the battery (**B-**, **B+**) and motor (**M-**, **A2**).

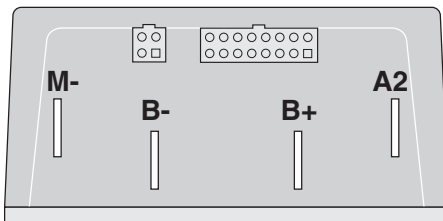

Cables are fastened to the bus bars by M8 ( $\frac{5}{16}$ " ) bolts. When tightening the bolts, two opposing wrenches should be used to prevent bending the bus bars and putting undue strain on the internal connections.

### 1227/37 Wiring Configurations

The 1227/37 controller can be configured to work with either on/off or momentary switches for selecting direction and mode. If a power enable switch is used, it must be momentary style. For more information on control switches, see p. 24.

#### With on/off switches

Typical wiring for the 1227/37 controller with on/off switches is presented in Figure 9. This diagram shows the controller configured with the program 1 driver as an electromagnetic brake, the program 2 driver as a brake light driver, and two SPST switches used for selecting direction. NOTE: In the configuration shown, the power enable pin is an output that drives the Status LED. With

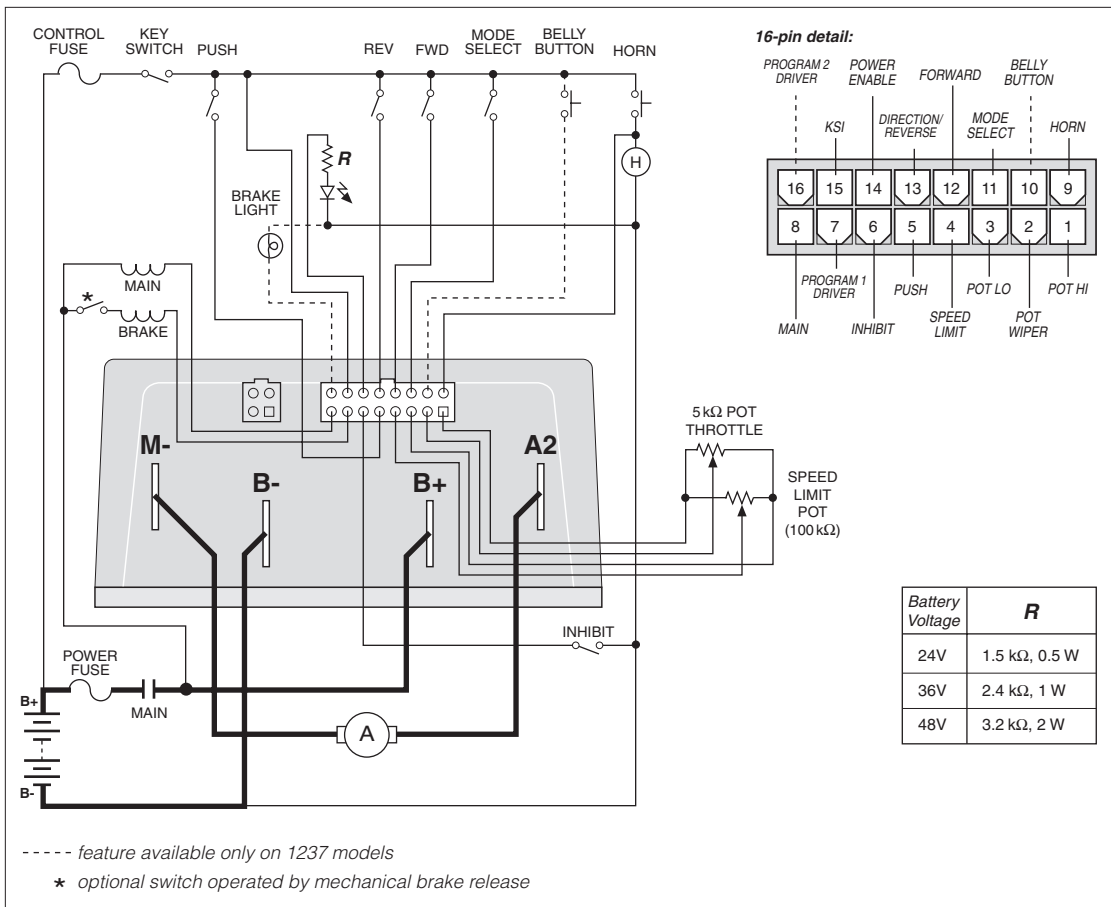

Fig. 9 Basic wiring configuration using on/off switches, Curtis 1227/37 controller.



on/off switches, the power enable function is performed by the keyswitch and a power enable switch is not used.

*With momentary switches*

Typical wiring for the 1227/37 controller with momentary switches is presented in Figure 10. This diagram shows the controller configured with the program 1 driver as an electromagnetic brake, the program 2 driver as a brake light driver, and a single direction switch. NOTE: When a momentary switch is used for the mode input, the controller will always power up in Mode 1 (the default mode).

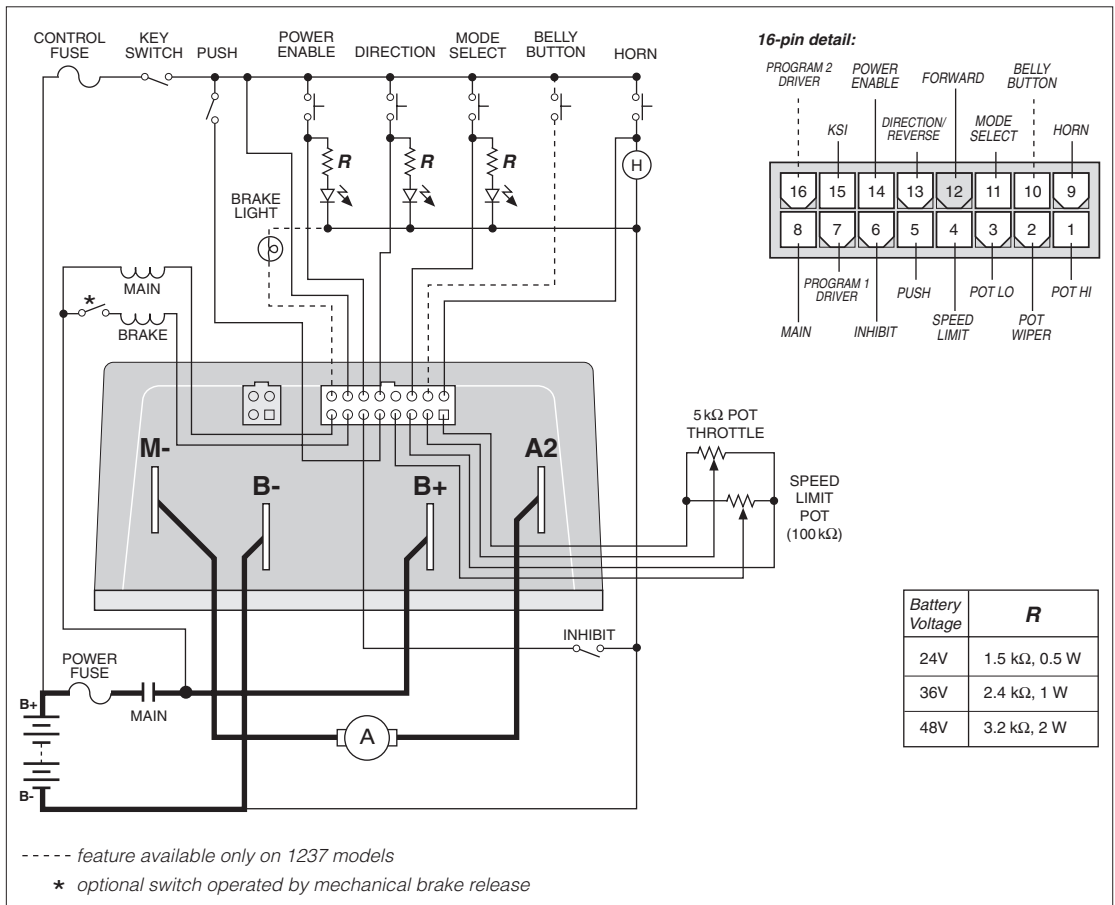

**Fig. 10** Basic wiring configuration using momentary switches, Curtis 1227/37 controller.

## THROTTLE WIRING

The 1223/33, 1225/35, and 1227/37 controllers are programmable to suit a variety of throttles. If the throttle you are planning to use is not covered, contact the Curtis office nearest you.

Mounting dimensions are provided in Appendix B for the standard 5k $\Omega$ , 3-wire throttle potentiometer, the Curtis potboxes and footpedals, and the electronic throttle ET-1XX.

For information on programming various throttle parameters, see Section 3: Programmable Parameters; the throttle parameters are on pages 33–39.

### 5k $\Omega$ , 3-Wire Potentiometer

A 5k $\Omega$ , 3-wire potentiometer is the standard throttle, and is shown in the basic wiring diagrams (Figures 3 & 4, 6 & 7, and 9 & 10). The controller can be programmed to be compatible with single-ended, wigwag, or inverted wigwag style throttles (*see page 33*). These throttle styles are defined in Table 2 (page 19). NOTE: The standard 8% neutral deadband and 100% throttle gain are assumed in the definitions; resistance is measured between pot low and pot wiper.

For wigwag and inverted wigwag applications, the pot can be correctly centered within the controller's neutral band by using the throttle autocalibration feature (*see page 35*). Pots with less than 5 k $\Omega$  total resistance change over the throttle's full stroke can be accommodated by programming the controller for reduced-range throttle inputs, via the throttle gain parameter (*see page 37*).

The controller provides full pot fault protection against open or shorted wires anywhere in the throttle assembly. The overall pot resistance can range from 4.5 k $\Omega$  to 7.0 k $\Omega$ . Values outside this range will trigger a fault condition. If a pot fault occurs while the vehicle is moving, the controller will decelerate the vehicle to neutral through its normal deceleration curve. If the fault is corrected while the throttle is still applied, the vehicle will accelerate to the requested speed.

### 0–5V Throttle

A 0–5V throttle input can be used instead of a pot, as shown in Figure 11. The controller can be programmed to be compatible with single-ended, wigwag, or inverted wigwag style throttles (*see page 33*). These throttle styles are defined in Table 2 (page 19). With a wigwag or inverted wigwag 0–5V input, the throttle output voltage must be 2.5 V ( $\pm$  deadband) in neutral and a 4.7k $\Omega$ , 0.25W resistor must be added between the pot high and pot low pins. A resistor is not required with a single-ended 0–5V input.

Voltage throttles with less than 5 V total voltage change over the full stroke can be accommodated by programming the controller for reduced-range throttle inputs, via the throttle gain parameter (*see page 37*).

**Fig. 11** Wiring for 0–5V throttle.

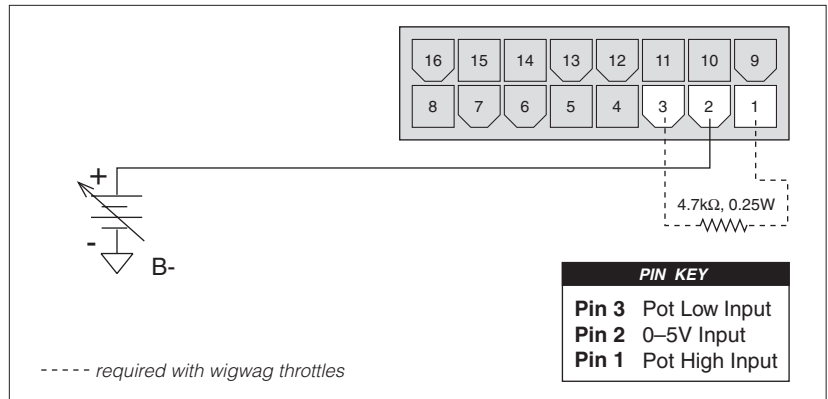

Because the throttle input voltage is referenced to B- and no throttle connections are made to the pot high and pot low inputs, throttle fault protection is lost with 0–5V throttles. The only throttle fault that will be detected by the controller is a broken wire to the pot wiper input (Pin 2), which will cause a normal deceleration to neutral. The controller will not recognize out-of-range throttle inputs as faults, and applying excessive voltages to the throttle wiper input may damage the controller. **It is the responsibility of the vehicle manufacturer to provide throttle fault detection for 0–5V throttles.**

**Table 2 THROTTLE STYLES for 3-wire, 5k $\Omega$  pots (0–5V throttles)**

THROTTLE STYLE	DESCRIPTION OF OPERATION
<i>Single-Ended</i>	Zero speed at any resistance less than 400 $\Omega$ (0.4 V). Controller output increases as resistance increases in the selected direction. Maximum output is reached at 4.8 k $\Omega$ (4.8 V).
<i>Wigwag</i>	Zero speed at 2.5 k $\Omega$ $\pm$ 200 $\Omega$ (2.5 V $\pm$ 0.2 V). Controller output increases in the forward direction as resistance increases, with maximum forward output reached at 4.8 k $\Omega$ (4.8 V). Output increases in the reverse direction as this resistance decreases, with maximum reverse output reached at 200 $\Omega$ (0.2 V).
<i>Inverted Wigwag</i>	Same as wigwag, with the exception that increasing the resistance increases controller output in the <u>reverse</u> direction, and decreasing resistance increases output in the <u>forward</u> direction.

### Curtis ET-XXX Electronic Throttle

The recommended wiring for the Curtis ET-XXX electronic throttle is shown in Figure 12. The ET-XXX throttle provides a single-ended 0–5V throttle signal and a signal indicating whether it is in forward or reverse. If the controller is configured to require only a single direction switch, only the reverse output wire (white wire) needs to be connected. If the controller is configured to require separate inputs for forward and reverse, the forward output wire (black/white wire) must also be connected. NOTE: The controller must be programmed as a single-ended 0–5V throttle type for use with the ET-XXX.

As with any 0–5V throttle, there is no fault detection built into the ET-XXX. It is the responsibility of the vehicle manufacturer to provide throttle fault detection when using the ET-XXX.

**Fig. 12** Wiring for Curtis ET-XXX electronic throttle.

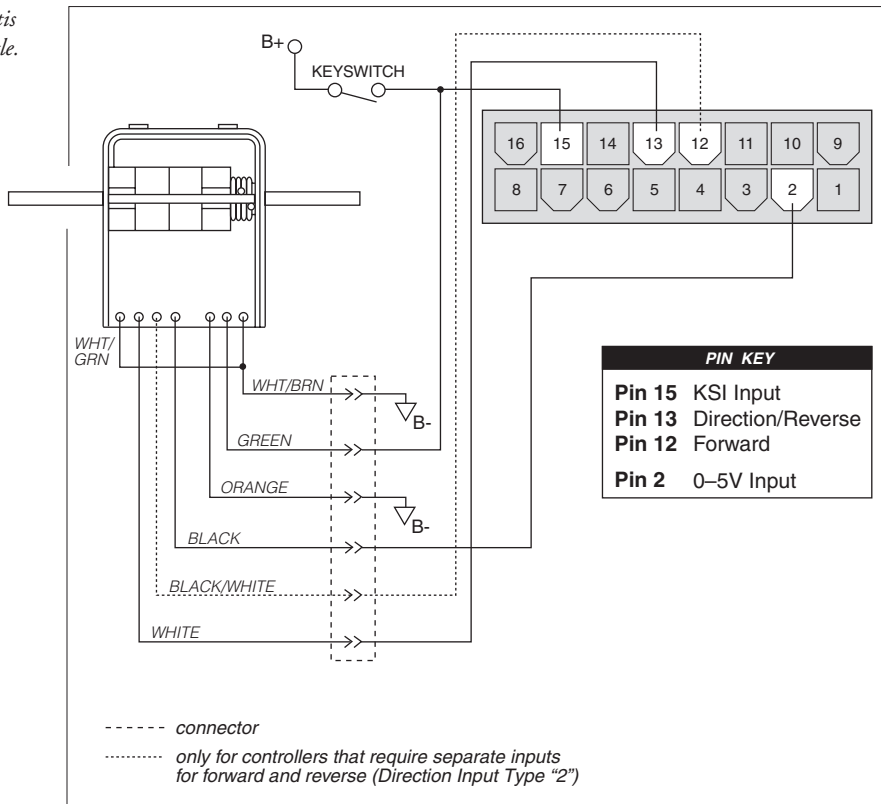

### Speed Limit Pot

A speed limit pot allows the operator to adjust the speed of the vehicle at full throttle. Wiring for the speed limit pot is shown in each of the basic wiring diagrams (Figures 3 & 4, 6 & 7, 9 & 10). The speed limit pot should be sized so that it does not affect the throttle input resistance and thus the throttle response. A 100k $\Omega$  pot is recommended.

The speed limit pot is at its maximum speed setting when its wiper is shorted to the throttle pot's pot high connection (Pin 1). When the speed limit pot is in its maximum speed position, the vehicle's speed at full throttle corresponds to the programmed maximum speed setting. The speed limit pot is at its minimum speed setting when its wiper is shorted to the throttle pot's pot low connection (Pin 3). When the speed limit pot is in its minimum speed position, the vehicle's speed at full throttle corresponds to the programmed minimum speed setting. For information on the programmable speed parameters, see Section 3.

The speed limit pot varies the vehicle's speed linearly over the range between the minimum and maximum speed settings in each mode. In the examples shown in Figure 13, the Mode 2 maximum and minimum speeds (M2 max, min) are set at 100% and 40%, and the Mode 1 maximum and minimum speeds (M1 max, min) are set at 60% and 20%.

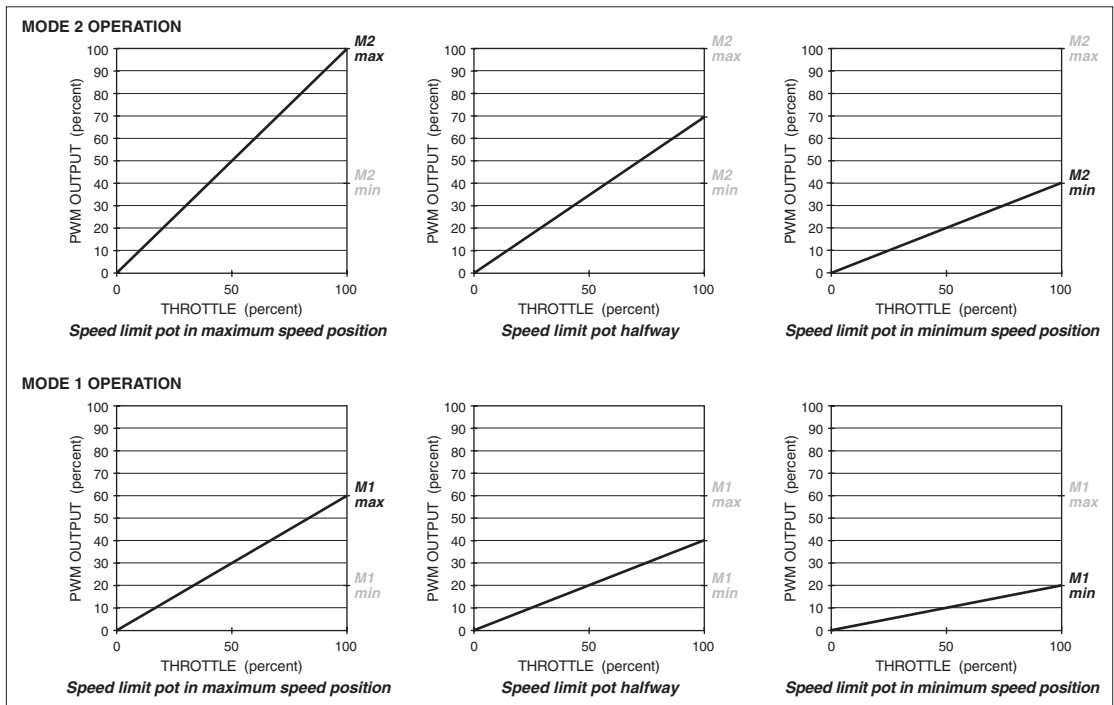
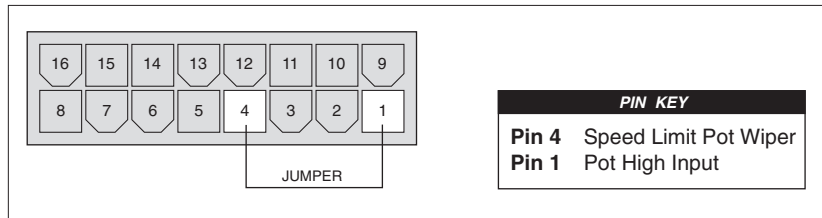

**Fig. 13** Effect of speed limit pot position on speed curves.

The speed limit pot also limits the vehicle’s reverse speed. Reverse speed is linearly proportional to the speed limit pot setting and is adjustable from the Mode 1 minimum speed (speed limit pot in its minimum speed position) to the programmed maximum reverse speed (speed limit pot in its maximum speed position).

If a speed limit pot is not used, the speed limit input (Pin 4) can be jumpered to the pot high input, as shown in Figure 14. In this configuration, the vehicle speed at full throttle is defined by the programmed maximum speed. If no jumper is used, the vehicle speed at full throttle will be limited to the programmed minimum speed, which by default will also apply to reverse.

**Fig. 14** *Wiring of speed limit input to enable maximum speed when no speed limit pot is used.*



If a speed limit pot will never be used in the application, the controller can be factory-configured without the speed limit feature (see Section 4), and the jumper will not be required. With such a controller, the vehicle speed at full throttle is defined by the programmed maximum speed, and it is possible to program the reverse speed to a lower value if so desired.

## AUXILIARY DRIVER OUTPUT OPTIONS

### Program 1

The program 1 parameter configures a low side driver output at Pin 7. This output driver is typically programmed to drive an electromagnetic brake (as shown in the basic wiring diagrams (Figures 3 & 4, 6 & 7, 9 & 10). Alternatively, the program 1 driver can be programmed to drive an hour meter, sweeper/scrubber brush motor contactor, brake light, etc. It is rated at 1 ampere and is protected from external shorts. See Section 3 for details on configuring this output.

### Program 2

The program 2 parameter configures a high side driver output at Pin 16 on the 123X-series controllers (1233, 1235, 1237). This driver can be programmed to drive an hour meter, belly button check output, sweeper/scrubber brush motor contactor, brake light, etc. It can also be configured to perform a BB wiring check (see below). The program 2 driver is rated at 2 amperes and is **not** short circuit protected. See Section 3 for details on configuring this output.

### Emergency Reverse (Belly Button) Wiring Check

The 123X controllers (1233, 1235, 1237) can be configured to perform a check on the emergency reverse input wiring by using the program 2 driver output. This check allows the controller to determine the continuity of the emergency reverse wiring. To implement this check, the program 2 driver output (Pin 16) must be connected to the belly button switch as shown in Figure 15. **NOTE:** If the connection is not made at the belly button switch as shown, the emergency reverse wiring check will not be complete.

The controller can be factory-configured to either inhibit driving or limit the driving speed to the specified emergency reverse speed if the wiring check circuitry detects a break in the emergency reverse input wiring; see Section 4.

**Fig. 15** *Wiring to check the emergency reverse input wiring.*

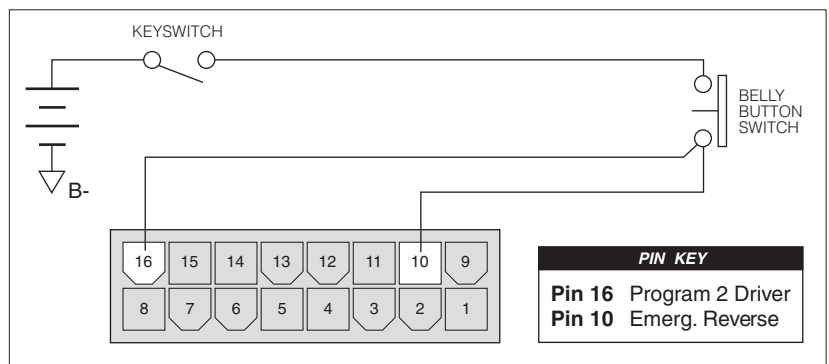

## SWITCHES AND OTHER HARDWARE

### Control Switches

The control switches must be sized to handle a minimum 150 mA of current to the controller plus the current required for the indicator LEDs and any other accessories that they drive.

The keyswitch must be an on/off switch. The power enable switch, if one is used, must be a momentary switch. The direction and mode select inputs can be factory-configured for use with either on/off or momentary switches. See Section 4, page 47, for information on specifying switch styles.

With the exception of the keyswitch input, each control input can be specified active high (enabled when connected to B+) or active low (enabled when connected to B-). The keyswitch input must be active high. The recommended configuration is for all the control inputs—except the inhibit input—to be set active high, although it is possible to specify any desired combination. See Section 4, page 47, for information on specifying these input polarities.

### Keyswitch and Power Enable Switch

Power to the controller can be provided via a single keyswitch or via a keyswitch and a power enable switch. If a keyswitch alone is used, enabling it will provide power to the controller's logic and enable the vehicle for driving. If both a keyswitch and a power enable switch are used, the keyswitch will provide power to the controller's logic but the power enable switch must also be activated in order to drive the vehicle.

The keyswitch should function as a master switch for the vehicle, to turn the system off when not in use. The keyswitch provides logic power for the controller and the other control input switches. An on/off switch must therefore be used for the keyswitch, and must be sized to carry the 150 mA quiescent logic current plus the current necessary to drive the precharge function (0.5 A for 0.5 seconds), any LED indicators, and any other accessories powered from the keyswitch line.

If a power enable switch is used, it must be configured as a momentary switch, so that the controller can supply diagnostic information via the Status LED flash codes.

### Push Switch

The push switch releases the electromagnetic brake electrically, thus precluding the necessity for a mechanical brake release. Activating the push input inhibits the controller's drive functions until the push switch is turned off. The push-too-fast feature limits the speed at which the vehicle can be pushed by shorting the motor if the push speed exceeds the preset threshold. **NOTE:** The controller must be connected to the batteries in order to use the push feature.



### Brake Release Switch (Brake Coil Disable Switch)

If a brake release lever is used to release the electromagnetic brake mechanically, a brake coil disable switch is recommended. This switch opens the electromagnetic brake coil when the mechanical brake release lever releases the brake from the motor shaft. The open brake coil will register as a fault, inhibiting controller operation if an operator attempts to drive the vehicle with the brake mechanically released. This safety feature ensures that the vehicle cannot be driven when the brake cannot be engaged. NOTE: A brake coil disable switch—or a self-resetting brake—is required to conform with TÜV regulations.

### Inhibit

The inhibit input can be used to inhibit controller operation for any reason. Typically it is used during battery charging, as shown in Figure 16. The inhibit input overrides all other controller inputs and is active when low (i.e., when within 1.0 V of B-). The input can be left floating when not engaged; it does not need to be pulled high.

**Fig. 16** Wiring to inhibit operation during battery charging.

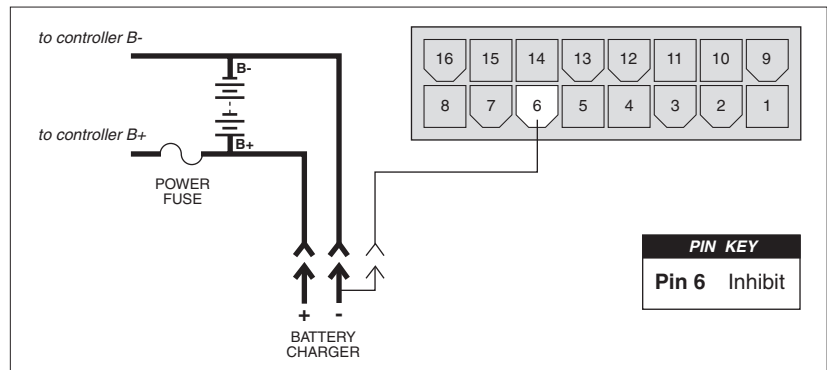

### Panel Indicator LEDs

The 1223/33, 1225/35, and 1227/37 controllers have the capability to drive indicator LEDs. These LEDs can be used as panel indicators to tell the operator, at a glance, the status, direction, and mode of the controller.

*Status LED* — This LED always indicates whether the controller is powered on or off. The Status LED will also provide diagnostics information via flash codes. See Section 7 for Status LED operation and fault codes.

*Direction LED* — This LED is lit when the controller is in reverse.

*Mode LED* — This LED is lit when the controller is in Mode 1.

If momentary switches are being used, the controller will drive the LEDs from an internal source. If on/off switches are used, the Direction LED and Mode Indicator LED are powered directly from the switches and only the Status LED is driven by the controller.

If indicator LEDs are used, they should be installed with the proper resistors in series. The controller's LED drivers are capable of providing a maximum current of 30 mA. The recommended resistors — designed to limit driver current to 15 mA when active — are listed in Table 3.

VOLTAGE	RESISTOR VALUE	POWER RATING
24V	1.5 k $\Omega$	0.5 W
36V	2.4 k $\Omega$	1.0 W
48V	3.3 k $\Omega$	2.0 W

### Horn

The controller's horn driver — Pin 9 — is designed to drive a piezoelectric horn. The horn sounds a warning when the reverse direction is selected (a series of beep tones) and when the throttle autocalibration feature is being used (a constant tone).

The horn driver provides a maximum current of 30 mA. Using a horn with a higher current requirement will damage and disable the driver.

### Main Contactor

An external main contactor is required with the 1227/37 controllers, and is shown in their wiring diagrams (Figures 9 and 10). A heavy-duty single-pole, single-throw (SPST) contactor with silver-alloy contacts is recommended, such as an Albright SW80 or SW180 (available from Curtis). This contactor does not require an external precharge resistor, because of the controllers' built-in precharging feature.

### Circuitry Protection Devices

To protect the control wiring from accidental shorts, a low current fuse (appropriately sized for the maximum control circuit current draw) should be connected in series with the battery feed. A fuse is also recommended for use in the high power connection from the battery to the controller's B+ terminal. This fuse will protect the power system from external shorts and should be sized appropriately for the maximum rated current of the controller.

# 3

## PROGRAMMABLE PARAMETERS

The 1223/33, 1225/35, and 1227/37 controllers have a number of parameters that can be programmed by means of a 1307 handheld programmer. These programmable parameters allow the vehicle's performance characteristics to be customized to fit the needs of individual vehicle operators.

Each controller is shipped with the parameter settings specified by the OEM. For each programmable parameter, the specification process includes designating whether it is to have User or OEM-only access rights. In consultation with Curtis applications engineers, the OEM specifies which—if any—parameters the user (dealer, distributor, etc.) will be able to adjust. Accordingly, Curtis offers two versions of the 1307 programmer: the 1307-1101 is the User programmer (which can adjust only those parameters with User access rights) and the 1307-2101 is the OEM programmer (which can adjust all the programmable parameters).

The MultiMode™ feature of these controllers allows operation in two distinct modes: “Mode 1” and “Mode 2.” These modes can be programmed to provide two different sets of operating characteristics, which can be useful for operation in different conditions. For example, a mobility aid scooter might have Mode 1 programmed such that the vehicle moves slowly for precise, indoor maneuvering and Mode 2 programmed for higher speed, long distance travel outdoors.

Seven parameters can be configured independently in the two modes:

- acceleration rate (M1, M2)
- forward deceleration rate (M1, M2)
- reverse deceleration rate (M1, M2)
- maximum speed (M1, M2)
- minimum speed (M1, M2)
- IR speed compensation (M1, M2)
- main current limit (M1, M2).

If a momentary switch is used to change modes, the controller defaults to Mode 1 when power is first applied. If an indicator LED is used with the momentary switch, it will be lit when the controller is in Mode 1.

If an on/off switch is used to change modes, the switch position determines the mode in which the controller powers up. The controller is in Mode 2 when the mode input is connected to B+ with the on/off switch type configured. Leaving the mode input floating or actively pulling it to B- puts the controller in Mode 1.

Controllers can be factory-set to allow only one mode of operation if a MultiMode™ system is not desirable for the application—see Section 4.

The programmable parameters are described in the following order. They are listed in the text by the abbreviated names that appear in the programmer's Program Menu. Not all of these parameters are displayed on all controllers; the list for any given controller depends on its specifications.

---

---

***Acceleration/Deceleration Parameters***

Acceleration Rate, M1/M2  
Forward Deceleration Rate, M1/M2  
Reverse Deceleration Rate, M1/M2

***Speed Parameters***

Maximum Speed, M1/M2  
Minimum Speed, M1/M2  
Reverse Speed  
Creep Speed  
Emergency Reverse Speed

***Throttle Parameters***

Throttle Type  
Direction Change Input Type  
Throttle Autocalibration  
Throttle Deadband  
Throttle Gain  
Ramp Shape (Static Throttle Map)

***Current Limit Parameters***

Main Current Limit, M1/M2  
Emergency Reverse Current Limit  
Calibration 5: Regen Current Limit Boost

***Output Driver Parameters***

Program 1 Auxiliary Driver  
Program 2 Auxiliary Driver  
Program 4: Brake Holding Voltage

***Fault Parameters***

High Pedal Disable (HPD)  
Static Return to Off (SRO)

***Other Parameters***

IR Compensation, M1/M2  
Calibration 4: IR Stiffness

---

---

### *Acceleration/Deceleration Parameters*

**M1 ACCEL RATE** [default access: User]

**M2 ACCEL RATE** [default access: User]

The **acceleration rate** defines the time it takes the controller to accelerate from 0% output to 100% output. A larger value represents a longer acceleration time and a gentler start. Fast starts can be achieved by reducing the acceleration time, i.e., by adjusting the accel rate to a smaller value. The accel rate is adjustable from 0.2 seconds to 3.0 seconds. The recommended range is 0.5–3.0 seconds, with accel rates less than 0.5 seconds allowed for abrupt acceleration under special circumstances.

**M1 DECEL** [default access: OEM]

**M2 DECEL** [default access: OEM]

The **deceleration rate** defines the time it takes the controller to decelerate from 100% output to 0% output when traveling in the forward direction. A larger value represents a longer deceleration time and a gentler stop. Reducing the decel rate will reduce the stopping distance required. The decel rate should be set at a value that will ensure the vehicle stops within a safe distance when traveling at maximum speed. (NOTE: The maximum allowed vehicle stopping distance may be defined by local regulations.) The decel rate is adjustable from 0.2 seconds to 3.0 seconds. The recommended range is 0.5–3.0 seconds, with decel rates less than 0.5 seconds allowed for abrupt stops under special circumstances.

**M1 REV DECEL** [default access: OEM]

**M2 REV DECEL** [default access: OEM]

The **reverse deceleration rate** defines the time it takes the controller to decelerate from maximum reverse speed to 0% output when traveling in the reverse direction. A larger value represents a longer deceleration time and a gentler stop. Reducing the reverse decel rate will reduce the stopping distance required. The reverse decel rate should be set at a value that will ensure the vehicle stops within a safe distance when traveling at maximum reverse speed. (NOTE: The maximum allowed vehicle stopping distance may be defined by local regulations.) Lower values may be required to ensure rapid stops when driving down ramps in reverse. The reverse decel rate is adjustable from 0.2 seconds to 3.0 seconds. The recommended range is 0.5–3.0 seconds, with reverse decel rates less than 0.5 seconds allowed for abrupt stops under special circumstances.

### Speed Parameters

**M1 MAX SPEED** [default access: OEM]

**M2 MAX SPEED** [default access: OEM]

The **maximum speed** parameter defines the maximum controller output at full throttle with the speed limit pot in its maximum speed position. For example, if Mode 1 Maximum Speed is set at 60% and the speed limit pot is in its maximum speed position, the controller will provide 60% output at full throttle in Mode 1. NOTE: If a speed limit pot is not used, the maximum speed parameter is not applicable unless Pin 4 is jumpered to Pin 1 (see page 22).

In the examples shown in Figure 17, the maximum speed parameter is set at 100% in Mode 2 and at 60% in Mode 1. The speed curves are straight lines in these examples because we are assuming a 50% ramp shape setting. The throttle response is not necessarily linear; see ramp shape parameter (page 38).

**Fig. 17** Examples of speed curves with the speed limit pot in its maximum speed position.

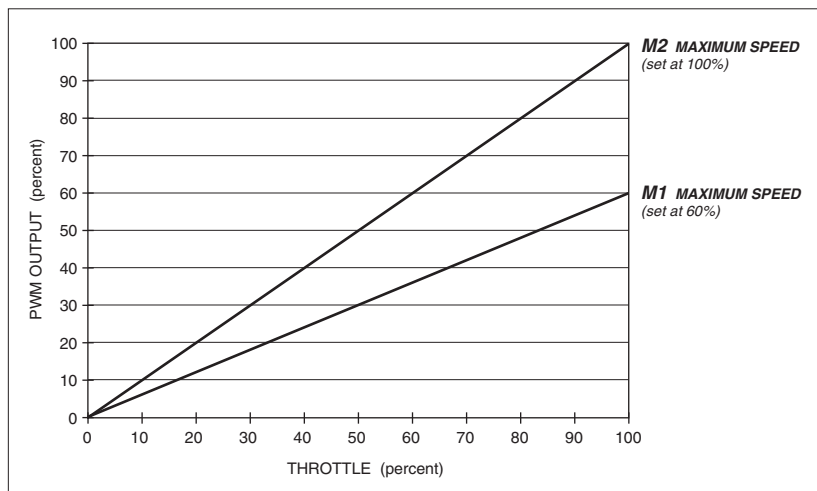

The speed interlocks (see Section 4) ensure that Mode 2 is by definition the faster of the two modes. The M1 Maximum Speed cannot be set higher than the M2 Maximum Speed.

**M1 MIN SPEED** [default access: User]

**M2 MIN SPEED** [default access: User]

The **minimum speed** parameter defines the maximum controller output at full throttle with the speed limit pot in its minimum speed position. For example, if Mode 1 Minimum Speed is set at 20% and the speed limit pot is in its minimum speed position, the controller will provide 20% output at full throttle.

NOTE: If a speed limit pot is not used, the minimum speed parameter defines the maximum controller output at full throttle unless Pin 4 is jumpered to Pin 1 (see page 22). If the Pin 4–1 jumper is used, the maximum speed parameter defines the maximum controller output at full throttle and the minimum speed parameter is not applicable.

In the examples shown in Figure 18, the minimum speed parameter is set at 50% in Mode 2 and at 20% in Mode 1. The speed curves are straight lines in these examples because we are assuming a 50% ramp shape setting. The throttle response is not necessarily linear; see ramp shape parameter (page 38).

**Fig. 18** *Examples of speed curves with the speed limit pot in its minimum speed position.*

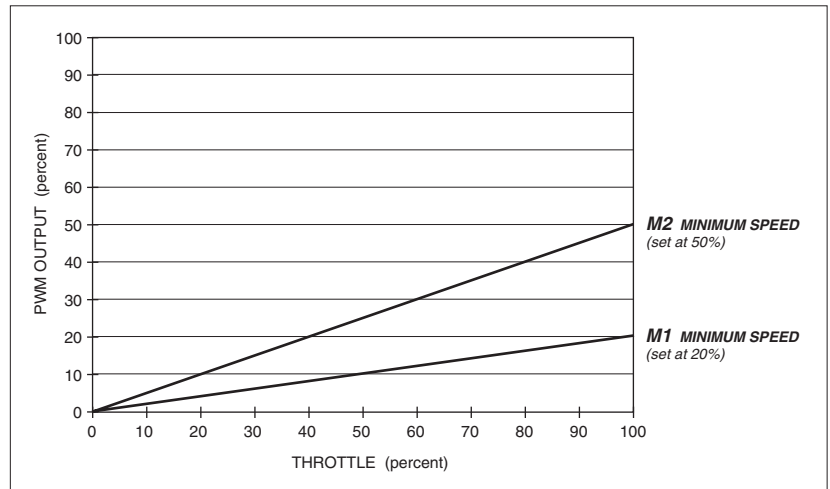

The speed interlocks (see Section 4) ensure that the minimum speed is set lower than the maximum speed in each mode (M1 Min Speed < M1 Max Speed, and M2 Min Speed < M2 Max Speed).

## REVERSE SPEED [default access: User]

The **reverse speed** parameter defines the maximum controller output in reverse at full throttle with the speed limit pot in its maximum speed position. Reverse speed is not affected by which mode (Mode 1, Mode 2) is selected. In the example shown in Figure 19, the reverse speed parameter is set at 40%.

The “minimum” speed in reverse (the speed at full throttle with the speed limit pot in its minimum speed position) is by definition equal to the M1 Minimum Speed.

The speed interlocks (see Section 4) ensure that the reverse speed parameter cannot be adjusted below the M1 Minimum Speed or 25% (whichever is higher) nor above the M1 Maximum Speed.

**Fig. 19** Example of reverse speed curve with the speed limit pot in its maximum speed position.

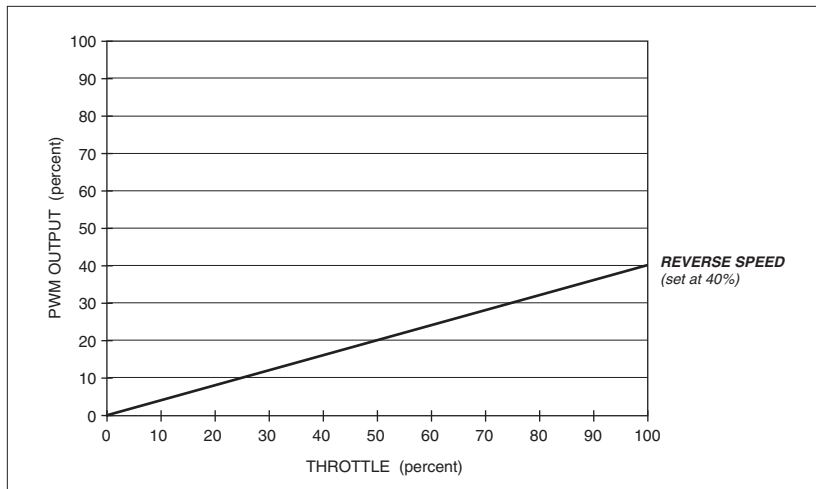

### **CREEP SPEED** [default access: OEM]

**Creep speed** helps to prevent vehicle rollback on inclines when the brake is released but low throttle is applied. It is activated when the throttle is rotated out of the throttle deadband (typically 8% of the full throttle range). The throttle response is rescaled so that the controller's output is adjustable over the full throttle range, but starting at the programmed creep speed value. Creep speed is programmable from 0% to 25% of the PWM duty cycle.

### **EMR REV SPEED** [default access: OEM]

*(123X models only)*

The **emergency reverse speed** parameter sets the speed at which the vehicle moves away from the operator when the belly button input (Pin 10) is active. The vehicle will move at this speed any time the belly button input is active, regardless of throttle position. The emergency reverse speed is adjustable from 0% to 100% of the PWM duty cycle. **NOTE:** If the controller is not factory-configured for the emergency reverse option, this parameter will not be displayed in the Program Menu.



*Throttle Parameters***CAUTION** 

**It is strongly recommended that the throttle type and direction parameters be adjusted only when the controller is in a bench test setup.** Changing these parameters while the controller is installed in the vehicle could result in vehicle runaway. If, for example, the throttle is a wigwag and the throttle type parameter is changed from wigwag to single-ended, the vehicle will register a throttle input and begin to move without any operator control. If it is necessary to adjust the throttle parameters with the controller in the vehicle, the vehicle drive wheels should be jacked up until the mechanical throttle, the programmed throttle type, and the programmed direction type all match.

**THROTTLE TYPE** [default access: OEM]

The controller can be programmed to accept single-ended, wigwag, or inverted wigwag signals from a 5k $\Omega$ , 3-wire pot or from a 0–5V voltage source. These throttle styles are described in Table 2 (page 19).

The **throttle input signal type** options—Types “0” through “3” in the Throttle Type programming menu—are listed in Table 4.

**Table 4 PROGRAMMABLE THROTTLE INPUT SIGNAL TYPES**

THROTTLE TYPE	APPLICABILITY		DESCRIPTION
	5k $\Omega$ 3-wire Pot	0–5V Throttle	
0	✓	✓	wigwag
1	✓	✓	inverted wigwag
2	✓		single-ended, with max. speed = 5k $\Omega$
3		✓	single-ended, with max. speed = 5V

**DIRECTION** [default access: OEM]

The **direction input type** defines how the controller decides when to change direction. For wigwag throttles, the direction input type defaults to respond to the throttle input. For single-ended throttles, this parameter can be set to either “single” or “dual.” The “single” setting allows the direction to be chosen via a single switch, which pulls the direction/reverse input (Pin 13) high when reverse is selected. It is not necessary for the switch to connect Pin 13 to B- when forward is selected. The “dual” setting requires input from two switches: one for reverse (Pin 13) and one for forward (Pin 12). In the dual configuration the switch must pull the forward or reverse input to B+ to select the direction. Selecting both forward and reverse at the same time will cause the controller to inhibit the output, disabling the vehicle until only one direction is selected. These three options—Types “0” through “2” in the Direction programming menu—are listed in Table 5.

DIRECTION INPUT TYPE	APPLICABILITY		DESCRIPTION
	Wigwag Throttle	Single-Ended Throttle	
0	✓		(responds to throttle input)
1		✓	“single” — allows direction to be selected via a single switch
2		✓	“dual” — requires direction to be selected via inputs from individual forward and reverse switches

**THRTL AUTOCAL** [default access: OEM]

The **throttle autocalibration** parameter provides a means of easily and reliably centering wigwag throttle pots. An audible tone and the Status LED assist the assembler in accurately centering the pot in the throttle assembly. The controller inhibits driving while in autocalibration mode, enabling the technician to adjust the throttle potentiometer safely.

Throttle centering is accomplished as follows:

1. Jack the vehicle drive wheels off the ground or disconnect the motor leads.
2. Completely assemble the throttle mechanism but do not tighten the clamping mechanism that secures the potentiometer shaft to the throttle lever.
3. Turn on the controller and plug in the 1307 handheld programmer.
4. Select the Program mode and scroll down to the throttle autocalibration parameter.
5. Turn the throttle autocalibration to On. At this point, the horn will probably sound and the LED will go off, indicating that the throttle pot is out of adjustment. If the horn does not sound and the LED remains on, the pot is already centered and no further adjustment is necessary.
6. With the throttle lever at the neutral position, adjust the potentiometer until the horn turns off and the LED goes on. The pot is now adjusted to the proper value for neutral.
7. Tighten the clamping mechanism which secures the throttle lever to the potentiometer shaft. Depress and release the throttle to verify the mechanical return to neutral.
8. Turn the throttle autocalibration parameter to Off. The vehicle will not drive if the throttle autocalibration parameter is left on.

### THRTL DEADBAND [default access: OEM]

The **throttle deadband** parameter defines the throttle pot wiper voltage range that the controller interprets as neutral. Increasing the throttle deadband setting increases the neutral range. This parameter is especially useful with throttle assemblies that do not reliably return to a well-defined neutral point, because it allows the deadband to be defined wide enough to ensure that the controller goes into neutral when the throttle mechanism is released.

Examples of deadband settings (20%, 15%, 8%) are shown in Figure 20, along with the formulas used to determine the wiper voltage range (with respect to B-) that the controller will interpret as neutral.

The programmer displays the throttle deadband parameter as a percentage of the nominal throttle wiper voltage range and is adjustable from 5% to 30% in 0.5% increments. The default deadband setting is 8%.

The nominal throttle wiper voltage range is 4 volts (from 0.5 V to 4.5 V) when measured relative to B-. This is true regardless of whether a single-ended or wigwag throttle is used. When a single-ended throttle is used, the deadband parameter sets a single threshold wiper voltage—that is, a wiper voltage (relative to B-) at which the controller will begin to modulate. When a wigwag throttle is used, the deadband parameter sets two threshold wiper voltages, one on either side of the 2.5 V (2.5 kΩ) centerpoint, for forward and reverse.

NOTE: The throttle characteristics are defined in terms of wiper voltage rather than throttle pot resistance because of the range of pot values that can be used and the variation between pots of the same nominal value. The voltage values

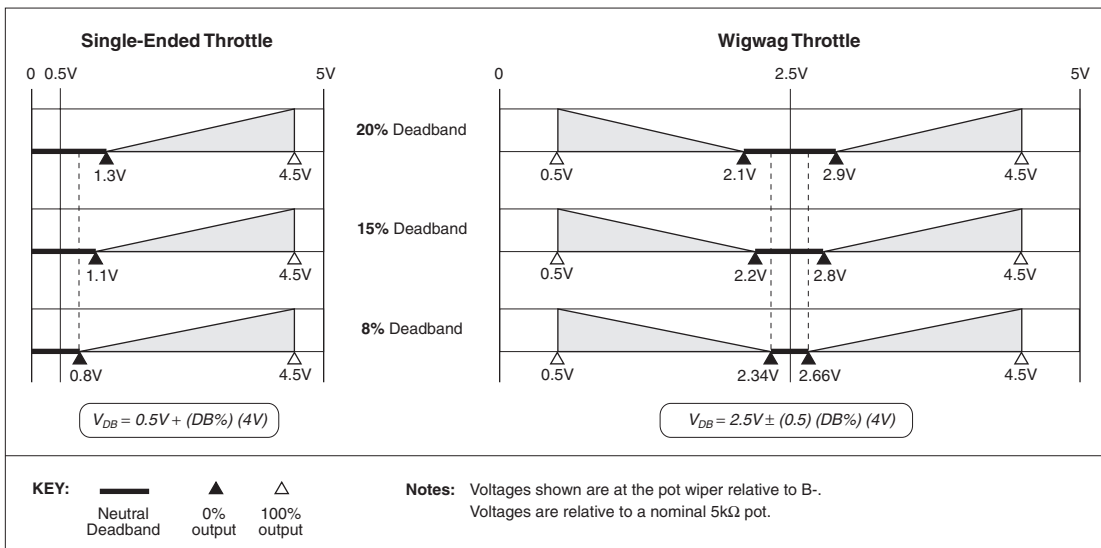

Fig. 20 Effect of adjusting the neutral deadband parameter.

shown in Figure 20 will hold true for any potentiometer value within the allowed 4.5 k $\Omega$  to 7.0 k $\Omega$  range.

### THRTL GAIN [default access: OEM]

The **throttle gain** parameter sets the wiper voltage required to produce 100% controller output. Decreasing the throttle gain setting reduces the wiper voltage and therefore the full stroke necessary to produce full controller output. This feature allows reduced-range throttle assemblies to be accommodated.

Examples of throttle gain settings are shown in Figure 20, to illustrate the effect of three different throttle gain settings (100%, 75%, 40%) on the full-stroke wiper voltage required to attain 100% controller output.

The programmer displays the throttle gain parameter as a percentage of the active throttle voltage range. The active throttle voltage range is the nominal voltage range (4V) minus the throttle deadband. As the throttle deadband is increased, the active throttle voltage range decreases. The throttle gain parameter can be adjusted from 10% to 100%, in 1% increments.

When a single-ended throttle is used, the throttle gain parameter sets the maximum pot wiper voltage required to produce 100% output. When a wigwag

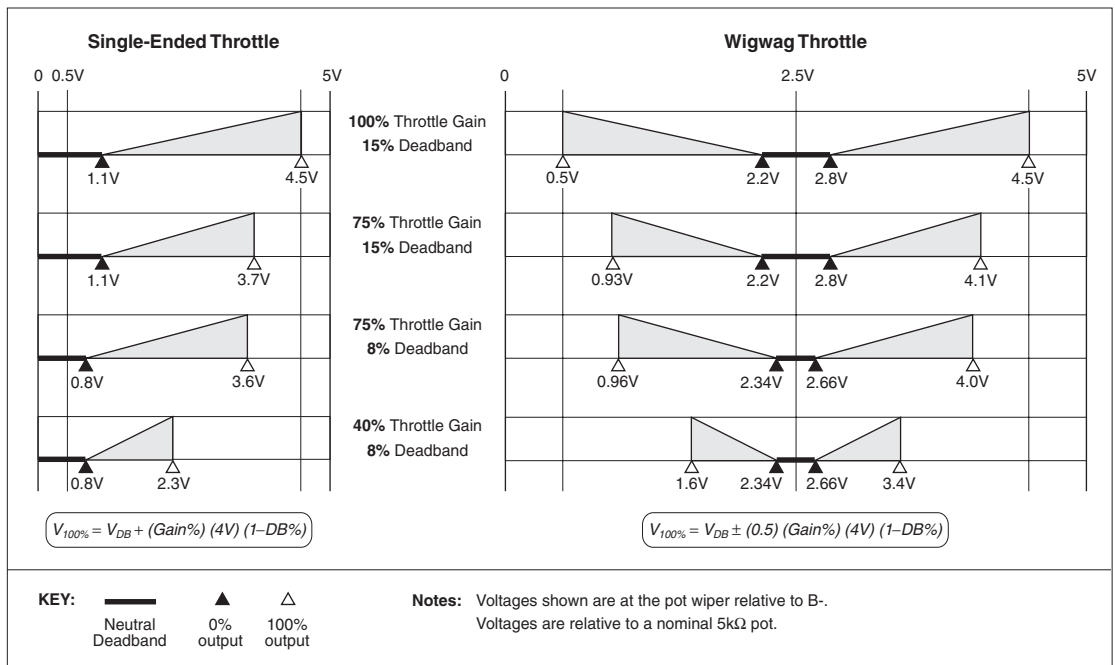

**Fig. 21** Effect of adjusting the throttle gain parameter.

throttle is used, the throttle gain parameter sets the pot wiper resistance required to produce 100% output in both forward and reverse: the wiper voltage required for full forward output is decreased, and the wiper voltage required for full reverse output is increased.

NOTE: The throttle characteristics are defined in terms of wiper voltage rather than throttle pot resistance because of the range of pot values that can be used and the variation between pots of the same value. The voltage values shown in Figure 21 will hold true for any potentiometer value within the allowed 4.5 kΩ to 7.0 kΩ range.

### RAMP SHAPE [default access: OEM]

The ramp shape parameter determines the static throttle map of the controller. This parameter modifies the vehicle’s response to the throttle input. Setting the ramp shape parameter at 50% provides a linear output response to throttle position. Values below 50% reduce the controller output at low throttle settings, providing enhanced slow speed maneuverability. Values above 50% give the vehicle a faster, jumpier feel at low throttle settings.

The ramp shape can be programmed in 1% increments between 20% and 70%. The ramp shape number refers to the PWM output at half throttle, as a percentage of its full range. For example, if maximum speed is set at 100% and creep speed is set at 0, a ramp shape of 50% will give 50% output at half throttle. The 50% ramp shape corresponds to a linear response. Six ramp shapes (20, 30, 40, 50, 60, and 70%) are shown as examples in Figure 22, with the maximum speed set at 100% and the creep speed set 0.

**Fig. 22** Ramp shape (throttle map) for controller with maximum speed set at 100% and creep speed set at 0.

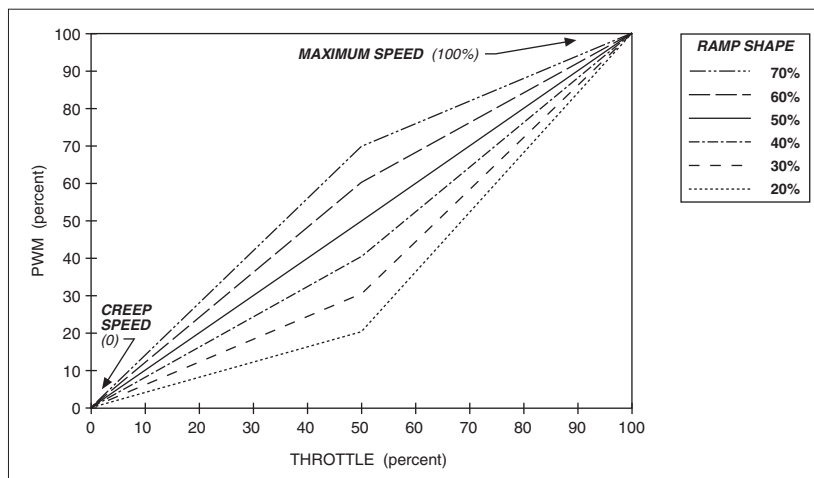

Changing either the maximum speed setting or the creep speed setting changes the output range of the controller. Ramp shape output is always a percentage of the output range (the range between the creep speed and maximum speed settings).

Ramp shapes with the creep speed setting raised from zero to 10% are shown in Figure 23.

**Fig. 23** Ramp shape (throttle map) for controller with maximum speed set at 100% and creep speed set at 10%.

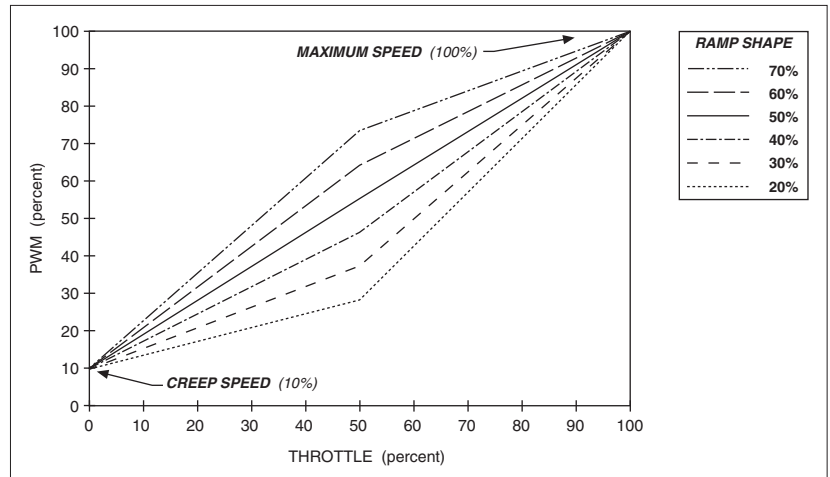

In Figure 24, the creep speed is kept at 10% and the maximum speed setting is dropped from 100% to 60%.

**Fig. 24** Ramp shape (throttle map) for controller with maximum speed set at 60% and creep speed set at 10%.

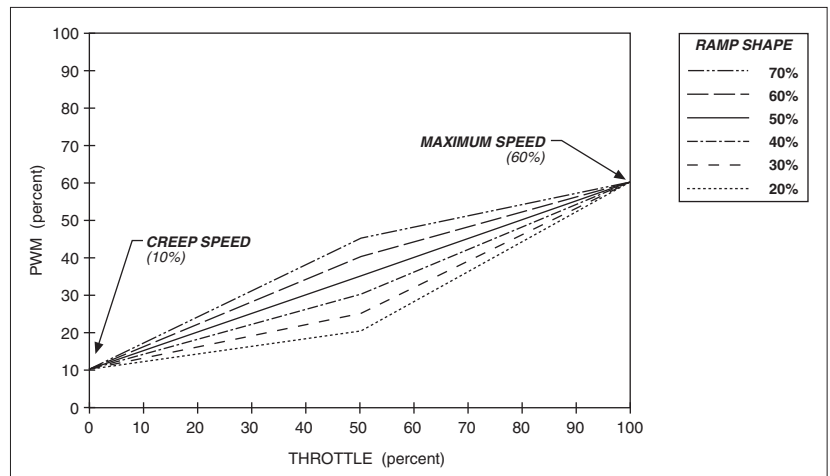

In all cases, the ramp shape number is the PWM output at half throttle, as a percentage of its full range. In Figure 24, for example, the 50% ramp shape gives

35% PWM output at half throttle (halfway between 10% and 60%). The 30% ramp shape gives 25% PWM at half throttle (30% of the range {which is 50%, from 10% to 60%}, starting at 10% output, or  $\{.30 \times 50\% + 10\% = 25\%$ ).

### *Current Limit Parameters*

**M1 MAIN C/L** [default access: OEM]

**M2 MAIN C/L** [default access: OEM]

The **main current limit** parameter allows adjustment of the maximum current the controller will supply to the motor during both drive and regen operation. This parameter can be limited to protect the motor from excessive (potentially damaging) currents or to reduce the maximum torque applied to the drive system by the motor. It is adjustable from 50% to 100% of the rated maximum controller current.

**EMR REV C/L** [default access: OEM]

*(123X models only)*

The **emergency reverse current limit** parameter defines the controller's current limit, regardless of the selected mode, when the belly button input (Pin 10) is active. The emergency reverse current limit is adjustable from 0% to the full rated controller current, regardless of the M1 and M2 main current limit settings. NOTE: If the controller is not factory-configured for the emergency reverse option, this parameter will not be displayed in the Program Menu.

**CALIBRATION 5** [default access: OEM]

The **regen current boost** parameter allows the regenerative braking current limit to be set higher than the main current limit. This feature can provide higher braking torque to stop heavy vehicles on steep inclines. The regen current boost parameter is adjustable from 0–25% above the programmed main current limit.



## Output Driver Parameters

### PROGRAM 1 [default access: OEM]

The **program 1** parameter configures an **auxiliary low side driver** (Pin 7). This output is rated at 1 amp and is short circuit protected. It can be programmed in any of seven configurations (Types 0–6 in the Program 1 Driver programming menu), as listed in Table 6.

Any component can be controlled by this output provided its current requirements do not exceed the driver's 1 amp rating.

**Table 6 CONFIGURATION OPTIONS: PROGRAM 1 DRIVER**

TYPE	TYPICAL USE	DESCRIPTION OF OPERATION
0	<i>Electromagnetic Brake Driver</i>	Turns on when direction is selected* and throttle is applied. Turns off, after the specified brake delay, when PWM output returns to zero or as commanded by the anti-rollback and anti-roll-forward circuitry.
1	<i>Brake Light Driver</i>	Turns on when controller is in braking mode. Turns off, after a half-second delay, when braking stops.
2	<i>Brush Motor Contactor Coil Driver: Option 1</i>	Turns on when direction is selected.* Turns off, without a delay, when PWM output returns to zero.
3	<i>Brush Motor Contactor Coil Driver: Option 2</i>	Turns on when direction is selected.* Turns off, after a 2 s delay, when PWM output returns to zero.
4	<i>Brush Motor Contactor Coil Driver: Option 3</i>	Turns on only when forward direction is selected.* Turns off, with no delay, in any other condition.
5	<i>Brush Motor Contactor Coil Driver: Option 4</i>	Turns on only when forward direction is selected.* Turns off, after a 2 s delay, in any other condition.
6	<i>Hour Meter</i>	Turns on when power is turned on. Turns off when power is turned off.

\* A direction is selected as follows:  
*for wigwag throttles*, when the throttle is rotated out of its neutral deadband;  
*for single-ended throttles*, when a direction input has been selected.

**PROGRAM 2** [default access: OEM]*(123X models only)*

The **program 2** parameter configures an **auxiliary high side driver** at Pin 16. This output is rated at 2 amps and is not short circuit protected. It can be programmed in any of eight configurations (Types 1–8 in the Program 2 Driver programming menu), as listed in Table 7.

Any component can be controlled by this output provided its current requirements do not exceed the driver's 2 amp rating. However, since this driver is not fault checked, it should not be used to drive an electromagnetic brake.

**Table 7 CONFIGURATION OPTIONS: PROGRAM 2 DRIVER**

TYPE	TYPICAL USE	DESCRIPTION OF OPERATION
0	N/A	N/A
1	<i>Brake Light Driver</i>	Turns on when controller is in braking mode. Turns off, after a half-second delay, when braking stops.
2	<i>Brush Motor Contactor Coil Driver: Option 1</i>	Turns on when direction is selected.* Turns off, without a delay, when PWM output returns to zero.
3	<i>Brush Motor Contactor Coil Driver: Option 2</i>	Turns on when direction is selected.* Turns off, after a 2 s delay, when PWM output returns to zero.
4	<i>Brush Motor Contactor Coil Driver: Option 3</i>	Turns on only when forward direction is selected.* Turns off, with no delay, in any other condition.
5	<i>Brush Motor Contactor Coil Driver: Option 4</i>	Turns on only when forward direction is selected.* Turns off, after a 2 s delay, in any other condition.
6	<i>Hour Meter: Option 1</i>	Turns on when power is turned on. Turns off when power is turned off.
7	<i>Hour Meter: Option 2</i>	Turns on when electromagnetic brake is released and a direction is selected.*
8	<i>Belly Button Check</i>	Periodically checks continuity of the wiring from the belly button switch to the controller's emergency reverse input.

\* A direction is selected as follows:  
*for wigwag throttles*, when the throttle is rotated out of its neutral deadband;  
*for single-ended throttles*, when a direction input has been selected.

**PROGRAM 4** [default access: OEM]

The **brake holding voltage** parameter allows selection of a voltage less than the full battery voltage to be applied to the brake coil when the brake is energized. This parameter is applicable only when the Program 1 driver is configured as an electromagnetic brake driver. The voltage is pulse width modulated and the setting represents the percentage of nominal battery voltage applied to the coil. Setting the parameter value to 100% allows the nominal battery voltage (e.g., 24V) to be applied to the coil whenever the battery voltage exceeds its nominal value. Setting the parameter value to 0% turns this feature off, causing the driver to apply the actual DC battery voltage to the brake coil when the brake is energized. When this parameter is set to a value greater than 0%, the nominal battery voltage is applied for 1 second (to ensure the brake coil disengages the brake) and then the programmed value is applied.

This feature provides greater vehicle range by reducing the power provided to the brake coil during operation. It also reduces brake heating, and thus reduces degradation of the brake's pull-in characteristics at high temperatures.

*Fault Parameters***HIGH PEDAL DIS** [default access: OEM]

The **high pedal disable (HPD)** feature prevents the vehicle from moving if the controller is turned on with the throttle applied. The HPD parameter allows HPD to be enabled or disabled with the programmer. When programmed On, HPD is active and controller output is inhibited if a throttle input greater than the throttle deadband exists before power is applied to the controller. If HPD is programmed Off, this protection feature is disabled and when the keyswitch (and power enable switch, if used) is turned on the controller output will accelerate normally to the commanded speed. NOTE: To meet TÜV requirements, the HPD feature must be programmed On.

**SRO** [default access: OEM]*(123X models only)*

The **static return to off (SRO)** feature prevents the vehicle from being started when “in gear.” If a direction is selected before the keyswitch and power enable switch (is one is used) are turned on, the SRO feature will inhibit the controller's output.

SRO can be set relative to either direction (Type “1” in the SRO programming menu) or to forward only (Type “2”). With SRO set to Type 2, operation is not inhibited if the reverse direction is selected prior to the keyswitch (and power enable switch, if applicable) being turned on. SRO can also be disabled (Type “0” is no SRO).

### *Other Parameters*

**M1 IR COEFF** [default access: OEM]

**M2 IR COEFF** [default access: OEM]

IR compensation is a method by which the controller maintains a constant vehicle speed despite changes in motor loading. The **IR speed coefficient** parameter adjusts how aggressively the controller tries to maintain constant speed under changing load conditions. This parameter should be set at or below the resistance (in milliohms) of the traction drive motor system including motor wiring and connections. The IR speed coefficient should never be set higher than this value, because jerky and uncomfortable or unsafe operation could result. The IR speed coefficient is adjustable down to 0, with 0 equaling no IR compensation.

**CALIBRATION 4** [default access: OEM]

The **IR stiffness** parameter allows adjustment of the IR compensation characteristics at low speeds or light loads. The IR stiffness parameter can be programmed from 0 to 32. Increasing the IR stiffness value makes the IR speed coefficient response more aggressive at low speeds or light loads, but it also makes the throttle response more harsh and abrupt. The IR stiffness value should therefore be set to maximize the IR compensation response while maintaining as smooth a throttle response as possible. For most applications, the midpoint setting (16) is a good compromise.

# 4

## OEM-SPECIFIED PARAMETERS (SET AT FACTORY)

In addition to the programmable parameters described in Section 3, there are various parameters that can be set at the factory per the OEM's specification. These parameters are not programmable with the 1307 programmer. If a change is desired, the controller must be returned to the factory for reconfiguration.

### *Speed Parameters*

#### **SPEED INTERLOCKS**

The speed interlocks prevent the speed parameters from being inadvertently programmed to give abnormal operating characteristics.

The following relationships are ensured by the speed interlocks.

---

*The minimum speeds can never be set higher than the corresponding maximum speeds:*

- M1 Min Speed cannot be set higher than M1 Max Speed
- M2 Min Speed cannot be set higher than M2 Max Speed

*Mode 2 is by definition the faster of the two modes:*

- M1 Max Speed cannot be set higher than M2 Max Speed

*Reverse speed, which applies in both modes, must be within the Mode 1 speed range, and can never be lower than 25%:*

- Reverse Speed must be set between M1 Min Speed and M1 Max Speed
  - Reverse Speed can never be set at less than 25%.
- 

The speed interlocks can be disabled at the factory, if so desired. However, this is not recommended unless a specific application requires that the existing speed interlock relationships be violated.

**OEM specifies** ► Enable: Yes or No      **Default setting** ► Enabled

#### **SPEED LIMIT POT FAULT**

The speed limit pot fault function provides a check to determine whether the speed limit pot wiper is correctly connected. If a wiper input is not detected, the controller limits its maximum speed to the specified minimum speed (i.e., the

controller responds as if the speed limit pot is at its minimum speed position) until the wiper wiring is repaired. No error code is given, either in the Diagnostics Menu of the 1307 programmer or by the Status LED. However, this fault can be verified by selecting the Test Menu and observing the speed limit pot value as the pot position is changed. If the speed limit pot value does not change as the pot is rotated through its range, a wiring problem may exist and the speed limit pot wiring should be checked. If a speed limit pot will never be used in the application, this fault check should be disabled at the factory.

**OEM specifies** ► Enable: Yes or No      **Default setting** ► Enabled

### *Fault Parameters*

#### **MAIN CONTACTOR FAULT CHECK**

The main contactor fault function checks for proper operation of the main contactor and the controller's contractor coil driver. If a welded contactor, missing or shorted contactor coil, or failed contactor coil driver is detected, the controller will inhibit output to the motor and flash the Hardware Failsafe 3 error code (3,3) via the Status LED. In applications for which these fault checks are undesirable and not required, the main contactor fault function can be disabled at the factory. However, it should be noted that this function is required to meet TÜV regulations.

**OEM specifies** ► Enable: Yes or No      **Default setting** ► Enabled

#### **OVERVOLTAGE**

Overvoltage can occur if the battery pack disconnects or the power fuse opens during regen braking. Controller operation resumes when the voltage is brought under the overvoltage limit. Overvoltage protection is designed to protect the controller from damage during brief periods of overvoltage. (NOTE: Attempts to operate the controller for extended periods in an overvoltage condition—such as trying to drive the vehicle with the charger attached and charging—will damage it.) The controller can be configured to short the motor or to let it coast in the event of overvoltage. The recommended setting is for overvoltage to short the motor, and this configuration is required to meet TÜV regulations.

**OEM specifies** ► Short or Coast      **Default setting** ► Short

#### **EMERGENCY REVERSE CHECK**

*(123X models only)*

This parameter is applicable only when the Program 2 driver is configured for emergency reverse. The emergency reverse check function defines how the controller reacts to a fault in the emergency reverse wiring. If configured as "Drive,"

the controller will limit the vehicle's maximum speed to the specified emergency reverse speed regardless of mode or direction. This allows the vehicle to be moved out of the way or driven back to the maintenance area for repair. If configured as "disable," the controller will inhibit all output to the motor until the emergency reverse wiring fault has been corrected.

**OEM specifies** ► Drive or Disable      **Default setting** ► Drive

### *Other Parameters*

#### **SWITCH TYPE**

The direction and mode selection switches can be specified as either momentary or on/off. If a power enable switch will be used, it must be specified as a momentary switch. Typically, the OEM specifies these three switches (direction, mode, power enable) to be all momentary or all on/off, and not a combination of the two styles. (NOTE: When on/off switches are specified, a power enable switch is not used and the power enable pin is an output that drives the Status LED.) Consult Curtis applications engineers if your application requires such a combination.

**OEM specifies** ► Momentary or On/Off

#### **INPUT POLARITIES**

With the exception of the keyswitch input (which must be active high), each of the controller's control signal inputs can be configured as active high or active low. If an input is configured to be active high, the control function is recognized when that input is pulled to battery B+. If an input is configured to be active low, the control function is recognized when that input is pulled to battery B-. The standard configuration is for all inputs to be active high with the exception of the inhibit input, which is active low. Although each input can be configured either active high or active low, there are some limitations on the allowable combinations.

**OEM specifies** ► Active: High or Low  
(for each input)      **Default setting** ► Active High  
(all except inhibit input)

#### **EMERGENCY REVERSE**

*(123X models only)*

This parameter defines whether the emergency reverse function is active. The emergency reverse feature is typically used on vehicles with tiller handle control and a belly button switch. This feature automatically transitions the vehicle to the reverse direction—away from the operator—when the belly button switch is engaged.

**OEM specifies** ► On or Off      **Default setting** ► Off

### KEY OFF DECEL

The key off decel function decelerates the vehicle to zero speed per the specified deceleration delay if the keyswitch is turned off while the vehicle is in motion. If the key off decel function is disabled, the controller shorts the motor if the keyswitch is turned off, causing a severely abrupt stop of the vehicle. It is therefore recommended that the key off decel function be enabled.

**OEM specifies** ► On or Off      **Default setting** ► On

### POWER SAVER

The power saver function releases the main contactor if the controller does not receive any throttle commands in a 25-second period; it shuts the controller off completely if no commands are received in a 25-minute period. This reduces the residual current draw on the batteries and extends vehicle range. The keyswitch must be cycled to activate the controller after the power saver has shut it down. If the power saver function is disabled, the controller will remain on as long as the keyswitch input is active.

**OEM specifies** ► Enable or Disable      **Default setting** ► Enable

### MULTIMODE™

A key feature of Curtis MultiMode™ controllers is their capability of being configured for optimized performance in two distinctly defined modes. However, should the OEM prefer to offer only a single mode of operation in a given application, the MultiMode™ feature can be disabled. Additionally, each of the seven MultiMode™ parameters can be individually defined as MultiMode™ or single mode.

**OEM specifies** ► On or Off      **Default setting** ► On



## 5

## INSTALLATION CHECKOUT

Before operating the vehicle, carefully complete the following checkout procedure. If you find a problem during the checkout, refer to the diagnostics and troubleshooting section (Section 7) for further information.

The installation checkout can be conducted with or without the handheld programmer. The checkout procedure is easier with a programmer. Otherwise, observe the LED for diagnostic codes. (The codes are listed in Section 7.)



**Put the vehicle up on blocks to get the drive wheels off the ground before beginning these tests.**

**Do not stand, or allow anyone else to stand, directly in front of or behind the vehicle during the checkout.**

**Make sure the keyswitch is off, the throttle is in neutral, and the forward/reverse switches are open.**

**Wear safety glasses and use well-insulated tools.**

1. If a programmer is available, connect it to the programmer connector.
2. Turn the keyswitch on. If your system includes a momentary power enable switch, you must press this switch also. The programmer should power up with an initial display, and the controller's Status LED should light up and remain steadily lit. If neither happens, check for continuity in the keyswitch circuit and controller ground.
3. If you are using a programmer, put it into the diagnostic mode by pressing the **DIAGNOSTICS** key. The display should indicate "No Faults Found."
 

If there is a problem, the LED will flash a diagnostic code and the programmer will display a diagnostic message. If you are conducting the checkout without a programmer, look up the LED diagnostic code in Section 7 (Diagnostics and Troubleshooting).

When the problem has been corrected, it may be necessary to cycle the keyswitch in order to clear the fault code.
4. Select a direction and operate the throttle. The motor should begin to turn in the selected direction. If it does not, verify the wiring to the throttle and motor. The motor should run proportionally faster with increasing throttle. If not, refer to Section 7.

5. If you are using a programmer, put it into the test mode by pressing the **TEST** key. Scroll down to observe the status of the switches: forward, reverse, inhibit, push enable, mode select, and emergency reverse (if applicable). Cycle each switch in turn, observing the programmer. The programmer should display the correct status for each switch.  
Similarly, check the program 1 and program 2 (if applicable) drivers and the throttle and speed limit pot inputs. The programmer should display the correct value for each driver and input.
6. Verify that all options, such as high pedal disable (HPD) and static return to off (SRO), are as desired.
7. Take the vehicle down off the blocks and drive it in a clear area. It should have smooth acceleration and good top speed.
8. Test the deceleration and regen braking of the vehicle. Verify that the deceleration and braking response is as desired.
9. If it is enabled, check to see whether the emergency reverse (belly button) feature is working correctly. If you have the optional emergency reverse check wiring, verify that the circuit is operational by momentarily disconnecting the emergency reverse wire leading to Pin 10. The vehicle should either be disabled or be limited to the specified emergency reverse speed and a fault indicated.
10. If you used a programmer, disconnect it when you have completed the checkout procedure.

### **BENCH TESTING WITH THE 1307 PROGRAMMER**

With the simple bench test setup shown in Figure 25, the controller parameters can be verified or adjusted without the controller being wired into a vehicle. The wiring can be expanded to conduct a complete functional test on the bench. Appropriately rated light bulbs, or a series of 12V bulbs, are an easily configured test load with which to check the controller's output power switching section and auxiliary drivers (program 1, program 2).

The complete in-vehicle installation checkout, as described above, should still be conducted before the vehicle is operated.

**Fig. 25** Bench test setup for verifying and adjusting the controller's parameters.

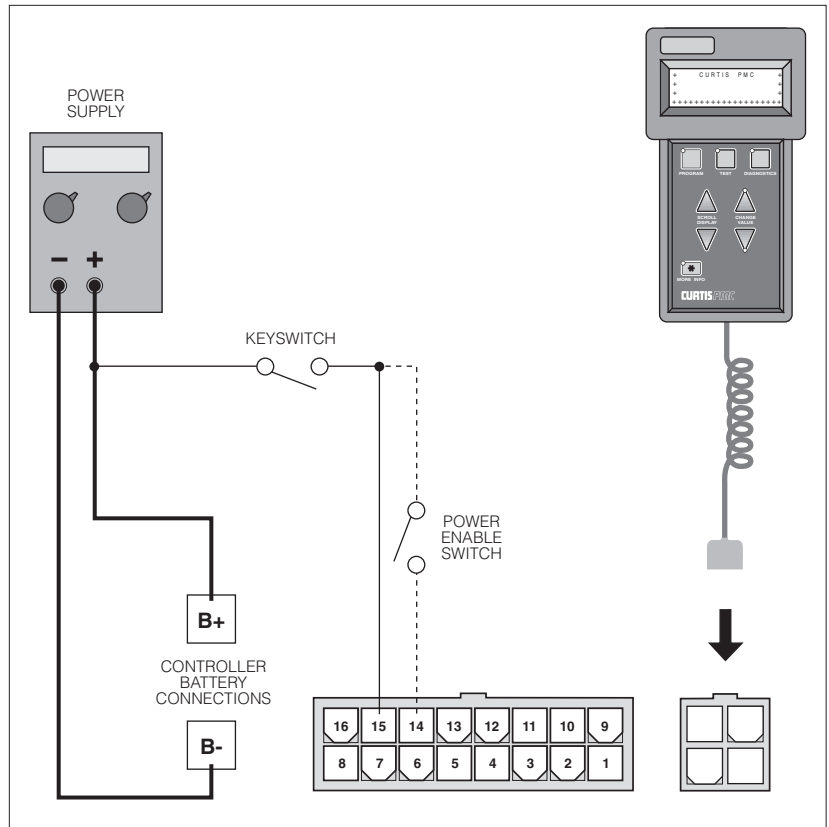

# 6

## PROGRAMMER OPERATION

The universal 1307 Curtis handheld programmer (optional) allows you to program, test, and diagnose Curtis programmable controllers. The programmer is powered by the host controller, via a 4-pin connector located on the controller.

When the programmer is first plugged into the controller, it displays the controller's model number, date of manufacture, and software revision code. Following this initial display, the programmer displays a prompt for further instructions.

**NOTE:** These controllers were developed for use with the 1307 handheld programmer. The 1307 has been superseded; if you are using a more recent programmer, please refer to the appropriate documentation.

The LED in the corner of the key lights up to identify the mode of operation

Scroll the 4-line display (up and down) with these two keys

A 4-line LCD display is presented in this window

Choose the Program, Test, or Diagnostics Mode with one of these three keys

Change the selected item's value (up or down) with these two keys

Get more information about selected items with this key. Also, use this key in combination with other keys to put the programmer in Special modes.

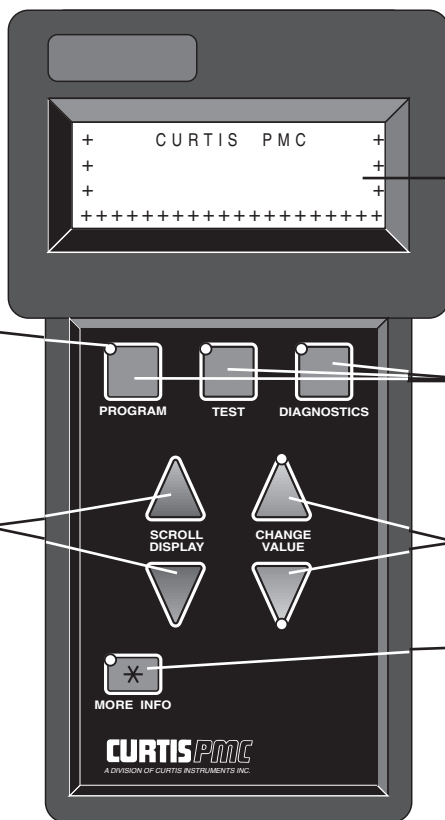

The programmer is operated via an 8-key keypad. Three keys select operating modes (Program, Test, Diagnostics), two scroll the display up and down, and two change the values of selected parameters. The eighth key, the **[MORE INFO]** key, is used to display further information about selected items within any of the three standard modes. In addition, when pressed together with the **[PROGRAM]** or the **[DIAGNOSTICS]** key, the **[MORE INFO]** key selects the Special Program mode or the Special Diagnostics mode.

The display window presents a 4-line LCD display. The display is visible even in bright sunlight. You can adjust the display contrast in the Special Program mode.

When one of the menu keys is pressed, the LED at the corner of the key lights up, identifying the mode of programmer operation. For example, if the **[TEST]** key is pressed, the LED at the corner of the key indicates that the programmer is now in the Test mode, and the Test Menu is displayed.

Four lines of a menu are displayed at a time. The item at the top of the display window is the selected item. To select an item, scroll within the menu until the desired item is positioned at the top of the display window. The selected item is always the top line. (In the Program mode, the selected item is highlighted by a flashing arrow.) To modify a parameter or obtain more information about it, it must be scrolled to the top position in the display window.



To scroll up and down within a menu, use the two **[SCROLL DISPLAY]** arrow keys. The **[SCROLL DISPLAY]** arrow keys can be pressed repeatedly or be held down. When a key is held down, the scrolling speed increases the longer the key is held.

A small scroll bar at the left of the display window provides a rough indication of the position of the four displayed items within the entire menu. That is, when the bar is at the top of the window, the top of the menu is displayed. As you scroll through the menu, the bar moves downward. When the bar is at the very bottom of the window, you have reached the end of the menu. This sample display is from the Program Menu:

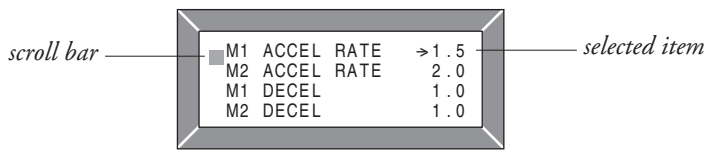



The two **CHANGE VALUE** arrow keys are used to increase or decrease the value of a selected menu item. Like the **SCROLL DISPLAY** arrow keys, the **CHANGE VALUE** arrow keys can be pressed repeatedly or be held down. The longer a key is held, the faster the parameter changes. This allows rapid changing of any parameter.

An LED on each **CHANGE VALUE** arrow key indicates whether the key is active and whether change is permissible. When the value of a parameter is being increased, the LED on the “up” **CHANGE VALUE** key is on until you reach the maximum value for that parameter. When the LED goes off, you cannot increase the value.

The **MORE INFO** key has three functions: (1) to display more information about the selected item, (2) to access the Special Program and Special Diagnostics modes (when used together with the **PROGRAM** and **DIAGNOSTICS** keys), and (3) to initiate certain commands (such as the Self Test).

“More information” is available in all of the programmer operating modes. After using the **MORE INFO** key to display additional information about the selected item, press the **MORE INFO** key again to return to the original list.

### OPERATING MODES:

PROGRAM, TEST, DIAGNOSTICS, SPECIAL PROGRAM, SPECIAL DIAGNOSTICS

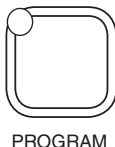

In the **Program** mode, accessed by pressing the **PROGRAM** key, all the adjustable parameters and features of the controller are displayed (four at a time), along with their present settings. The setting of the selected item—the item at the top of the display, with the flashing arrow—can be changed, using the two **CHANGE VALUE** keys.

The LEDs on these keys indicate whether there is still room for change. That is, when the upper limit of a parameter’s range is reached, the LED on the “up” key no longer lights up, indicating that the present value cannot be increased; when the lower limit is reached, the LED on the “down” key no longer lights up.

The **MORE INFO** key, when used in the Program mode, displays a bar graph along with the minimum and maximum values possible for the selected parameter. Parameters can be changed either from the main Program Menu or after the **MORE INFO** key has been pressed and the additional information is being displayed (see example below).

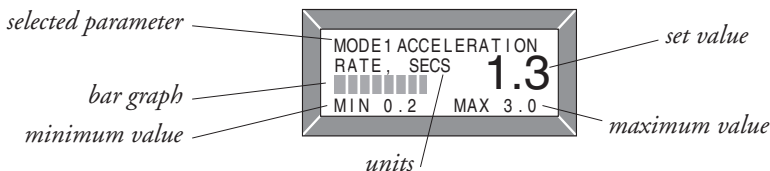

Some parameters on some controllers have dependencies on other parameters. This means that the available settings for one parameter may be dependent on the limits of another parameter. For example, your controller may not allow the reverse speed to be set below the Mode 1 minimum speed. In this example, if you attempt to reduce the reverse speed below the M1 minimum speed, a message will be displayed indicating that the minimum reverse speed is dependent on the M1 minimum speed.

The Program Menu is presented at the end of this section. NOTE: Some items may not be available on all models.

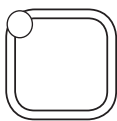

TEST

In the **Test** mode, accessed by pressing the **TEST** key, real-time information is displayed about the status of the inputs, outputs, and controller temperature. For example, when the status of the reverse input is displayed, it should read “On/Off/On/Off/On/Off” as the switch is repeatedly turned on and off. In the Test mode, the item of interest does not need to be the top item on the list; it only needs to be among the four items visible in the window. The Test mode is useful for checking out the operation of the controller during initial installation, and also for troubleshooting should problems occur.

The **MORE INFO** key, when used in the Test mode, causes additional information to be displayed about the selected item (top line in the window).

The Test Menu is presented at the end of this section. NOTE: Some items may not be available on all models.

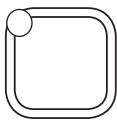

DIAGNOSTICS

In the **Diagnostics** mode, accessed by pressing the **DIAGNOSTICS** key, currently active faults detected by the controller are displayed.

The **MORE INFO** key, when used in the Diagnostics mode, causes additional information to be displayed about the selected item.

A list of the abbreviations used in the Diagnostics display is included at the end of this section.

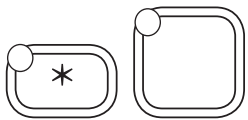

MORE INFO

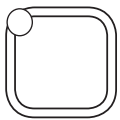

PROGRAM

The **Special Program** mode allows you to perform a variety of tasks, most of which are self-explanatory. Through the Special Program Menu, you can revert to earlier settings, save controller settings into the programmer memory, load the controller settings from the programmer into a controller, clear the controller’s diagnostic history, adjust the contrast of the programmer’s LCD display, select the language to be displayed by the programmer, and display basic information (model number, etc.) about the controller and the programmer.

To access the Special Program mode, first press the **MORE INFO** key. Then, while continuing to hold the **MORE INFO** key, press the **PROGRAM** key. The LED on the **PROGRAM** key will light, just as when the programmer is in Program mode. To distinguish between the Program and Special Program modes, look at the menu items in the display.

### CONTROLLER CLONING

Two of the Special Program Menu items—“Save Controller Settings in Programmer” and “Load Programmer Settings into Controller”—allow you to “clone” controllers. To do this, simply program one controller to the desired settings, save these settings in the programmer, and then load them into other similar (same model number) controllers, thus creating a family of controllers with identical settings.

The **MORE INFO** key is used initially to access the Special Program mode, and once you are within the Special Program mode, it is used to perform the desired tasks. To adjust the contrast in the display window, for example, select “Contrast Adjustment” by scrolling until this item is at the top of the screen, and then press **MORE INFO** to find out how to make the adjustment.

The Special Program Menu is presented at the end of this section.

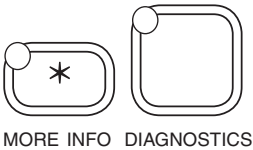

MORE INFO DIAGNOSTICS

In the **Special Diagnostics** mode, the controller’s diagnostic history file is displayed. This file includes a list of all faults observed and recorded by the controller since the history was last cleared. (NOTE: The maximum and minimum temperatures recorded by the controller are included in the Test Menu.) Each fault is listed in the diagnostic history file only once, regardless of the number of times it occurred.

To access Special Diagnostics, first press the **MORE INFO** key. Then, while continuing to hold the **MORE INFO** key, press the **DIAGNOSTICS** key. The LED on the **DIAGNOSTICS** key will light, just as when the programmer is in Diagnostics mode.

The **MORE INFO** key, when used within the Special Diagnostics mode, causes additional information to be displayed about the selected item.

To clear the diagnostic history file, put the programmer into the Special Program mode, select “Clear Diagnostic History,” and press the **MORE INFO** key for instructions. Clearing the diagnostic history file also resets the maximum/minimum temperatures in the Test Menu.



## PEACE-OF-MIND PROGRAMMING

Each time the programmer is connected to the controller, it acquires all the controller's parameters and stores them in its temporary memory. You can revert back to these original settings at any time during a programming session via the Special Program Menu. Select "Reset All Settings" by scrolling it to the top of the display window, press the **[MORE INFO]** key, and follow the instructions displayed. Any inadvertent changing of parameters can be "undone" using this procedure—even if you can't remember what the previous settings were—as long as the programmer has not been unplugged and power has not been removed from the controller.

### Programmer Self Test

You can test the programmer by displaying two special test screens. Press the **[MORE INFO]** key while the programmer is powering up. During the Self Test, you can toggle between the two test screens by pressing the **[SCROLL DISPLAY]** keys. The first screen turns on every LCD element, and the second screen displays all the characters used in the various menus. As part of the Self Test, you can also test the keys by pressing each one and observing whether its corner LED lights up. To exit the Self Test, unplug the programmer or turn off the controller, and then re-power it without holding the **[MORE INFO]** key.

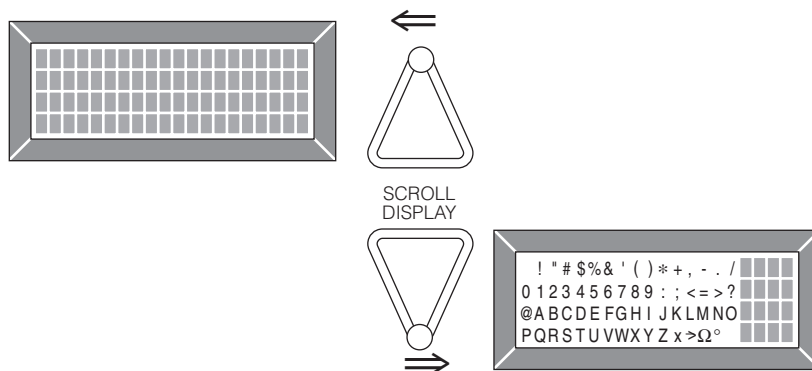

## PROGRAMMER MENUS

Items are listed for each menu in the order they appear in the actual menus displayed by the 1307 programmer.

**Program Menu** (not all items available on all controllers)

THRTL AUTO CAL	Wigwag throttle centering utility, On or Off
M1 ACCEL RATE	Mode 1 acceleration rate, in seconds
M2 ACCEL RATE	Mode 2 acceleration rate, in seconds
M1 DECEL	Mode 1 forward deceleration rate, in seconds
M2 DECEL	Mode 2 forward deceleration rate, in seconds
M1 REV DECEL	Mode 1 reverse deceleration rate, in seconds
M2 REV DECEL	Mode 2 reverse deceleration rate, in seconds
M1 MAX SPEED	Mode 1 maximum speed, as % PWM output
M2 MAX SPEED	Mode 2 maximum speed, as % PWM output
M1 MIN SPEED	Mode 1 minimum speed, as % PWM output
M2 MIN SPEED	Mode 2 minimum speed, as % PWM output
M1 MAIN C / L	Mode 1 main current limit
M2 MAIN C / L	Mode 2 main current limit
M1 IR COEFF	Mode 1 IR compensation factor, in m $\Omega$
M2 IR COEFF	Mode 2 IR compensation factor, in m $\Omega$
REVERSE SPEED	Maximum reverse speed, as % PWM output
RAMP SHAPE	Throttle map
CREEP SPEED	Creep speed, as % PWM output
EMR REV C / L	Emergency reverse current limit
EMR REV SPEED	Emergency reverse speed, as % PWM output
THROTTLE TYPE	Throttle type <sup>1</sup>
DIRECTION	Direction input type <sup>2</sup>
THRTL GAIN	Restricted range throttle adjustment, as % 5k $\Omega$ pot
THRTL DEADBAND	Neutral deadband adjustment, as % of throttle gain
HIGH PEDAL DIS	High pedal disable (HPD), On or Off
SRO	Static return to off (SRO) type <sup>3</sup>
PROGRAM 1	Program 1 driver type <sup>4</sup>
PROGRAM 2	Program 2 driver type <sup>5</sup>
PROGRAM 4	Brake coil holding voltage, as % nominal $V_{BAT}$
CALIBRATION 5	Regen current limit boost, as % > main c/l
CALIBRATION 4	IR stiffness

(Notes are on the next page.)

## Program Menu Notes

(For more detail on these options, see Section 3: Programmable Parameters.)

### <sup>1</sup> Throttle types

- Type 0:* wigwag (5k $\Omega$  pots or 5V throttles)
- Type 1:* inverted wigwag (5k $\Omega$  pots or 5V throttles)
- Type 2:* single-ended (0–5k $\Omega$ )
- Type 3:* single-ended (0–5V)

### <sup>2</sup> Direction input types

- Type 0:* wigwag throttle input
- Type 1:* single direction input
- Type 2:* dual direction input

### <sup>3</sup> SRO types

- Type 0:* no SRO
- Type 1:* SRO on KSI/power enable input plus direction input
- Type 2:* SRO on KSI/power enable input plus forward direction input

### <sup>4</sup> Program 1 driver types

- Type 0:* electromagnetic brake driver
- Type 1:* brake light driver
- Type 2:* brush contactor driver, off at neutral with no delay
- Type 3:* brush contactor driver, off at neutral with 2 second delay
- Type 4:* brush contactor driver, off at neutral and reverse with no delay
- Type 5:* brush contactor driver, off at neutral and reverse with 2 second delay
- Type 6:* hour meter driver, off when power enable is off

### <sup>5</sup> Program 2 driver types

- Type 1:* brake light driver
- Type 2:* brush contactor driver, off at neutral with no delay
- Type 3:* brush contactor driver, off at neutral with 2 second delay
- Type 4:* brush contactor driver, off at neutral and reverse with no delay
- Type 5:* brush contactor driver, off at neutral and reverse with 2 second delay
- Type 6:* hour meter driver, off when power enable is off
- Type 7:* hour meter driver, off when electromagnetic brake is engaged
- Type 8:* belly button wiring check

**Test Menu** (not all items available on all controllers)

THROTTLE %	Throttle reading, in percent of full
SPD LIMIT POT	Speed limit percent: 0–100%
BATT VOLTAGE	Battery voltage across the capacitors
MOTOR VOLTAGE	Motor voltage
HEAT SINK °C	Heatsink temperature
MODE INPUT A	Mode input: on/off
FORWARD INPUT	Forward input: on/off
REVERSE INPUT	Reverse input: on/off
INHIBIT	Inhibit input: on/off
MAIN CONT	Main contactor: on/off
* EM BRAKE DRVR	Program 1 driver: on/off
* AUX CONT A	Program 2 driver: on/off
PUSH ENABLE IN	Push enable input: on/off
EMR REV INPUT	Emergency reverse input: on/off

\* These text displays are fixed and will appear regardless of how the program 1 and program 2 drivers are actually configured. See Section 3 for a detailed description of the options available.

**Special Program Menu**

RESET ALL SETTINGS	Revert to original settings
CONT SETTINGS > PROG	Save controller settings in programmer
PROG SETTINGS > CONT	Load programmer settings in controller
CLEAR DIAG HISTORY	Clear diagnostic history memory
CONTRAST ADJUSTMENT	Adjust display contrast
LANGUAGE SELECTION	Select displayed language
PROGRAMMER INFO	Display programmer information
CONTROLLER INFO	Display controller information

### ***Diagnostics and Special Diagnostics “Menu”***

This is not a menu as such, but simply a list of the possible messages you may see displayed when the programmer is operating in either of the Diagnostics modes. The messages are listed in alphabetical order for easy reference.

BB WIRING CHECK	BB wiring check failed
EM BRAKE DRVR FAULT	Electromagnetic brake driver fault
HARDWARE FAILSAFE 1	EEPROM fault
HARDWARE FAILSAFE 2	Output section fault
HARDWARE FAILSAFE 3	Main contactor fault
HARDWARE FAILSAFE 4	Overcurrent fault
HPD	High pedal disable (HPD) activated
HW FAILSAFE	Motor voltage fault
LOW BATTERY VOLTAGE	Battery voltage too low <sup>a</sup>
NO KNOWN FAULTS	No known faults
OVERVOLTAGE	Battery voltage too high <sup>b</sup>
PRECHARGE FAULT	Precharge fault
PROC / WIRING FAULT	HPD fault present >5 seconds
SRO	Static return to off (SRO) activated
THERMAL CUTBACK	Cutback, due to over/under temp
THROTTLE FAULT 1	Throttle fault

<sup>a</sup> <16 volts (24V models); <21 volts (36V models); <27 volts (48V models)

<sup>b</sup> >36 volts (24V models); >48 volts (36V models); >60 volts (48V models)

# 7

## DIAGNOSTICS AND TROUBLESHOOTING

The 1223/33, 1225/35, and 1227/37 controllers provide diagnostics information to assist technicians in troubleshooting drive system problems. The diagnostics information can be obtained in two ways: observing the fault codes issued by the Status LED or reading the appropriate display on the handheld programmer.

### PROGRAMMER DIAGNOSTICS

The programmer presents complete diagnostic information in plain language. Faults are displayed in the Diagnostic Menu, and the status of the controller inputs/outputs is displayed in the Test Menu.

Accessing the Diagnostic History Menu provides a list of the faults that have occurred since the diagnostic history file was last cleared. Checking (and clearing) the diagnostic history file is recommended each time the vehicle is brought in for maintenance.

The following 4-step process is recommended for diagnosing and troubleshooting an inoperative vehicle: (1) visually inspect the vehicle for obvious problems; (2) diagnose the problem, using the programmer; (3) test the circuitry with the programmer; and (4) correct the problem. Repeat the last three steps as necessary until the vehicle is operational.

**Example:** A vehicle that does not operate in “forward” is brought in for repair.

**STEP 1:** Examine the vehicle and its wiring for any obvious problems, such as broken wires or loose connections.

**STEP 2:** Connect the programmer, select the Diagnostics Menu, and read the displayed fault information. In this example, the display shows “No Known Faults,” indicating that the controller has not detected anything out of the norm.

**STEP 3:** Select the Test Menu, and observe the status of the inputs and outputs in the forward direction. In this example, the display shows that the forward switch did not close when “forward” was selected, which means the problem is either in the forward switch or the switch wiring.

**STEP 4:** Check or replace the forward switch and wiring and repeat the test. If the programmer shows the forward switch closing and the vehicle now drives normally, the problem has been corrected.

Refer to the troubleshooting chart (Table 8) for suggestions covering a wide range of possible faults.

**Table 8 TROUBLESHOOTING CHART**

LED CODE	PROGRAMMER LCD DISPLAY	EXPLANATION	POSSIBLE CAUSE
1,1	HARDWARE FAILSAFE 2	output fault	1. Short in motor or in motor wiring. 2. Controller failure.
	HARDWARE FAILSAFE 4	overcurrent fault	1. Short in motor or in motor wiring. 2. Controller failure.
1,2	HARDWARE FAILSAFE 1	EEPROM fault	1. EEPROM failure or fault.
	HARDWARE FAILSAFE 3	main contactor fault	1. Main contactor welded. 2. Main contactor driver fault. 3. Main contactor coil fault.
	PRECHARGE FAULT	precharge fault	1. Internal controller fault. 2. Low battery voltage.
	HW FAILSAFE	motor voltage fault	1. Motor voltage does not correspond to throttle request. 2. M1 or M2 output shorted to B- or B+. 3. Internal motor short. 4. Controller failure.
2,1	SRO	SRO fault	1. Improper sequence of KSI, power enable, and direction inputs. 2. Wrong SRO type selected. 3. Direction switch circuit open.
2,2	HPD	HPD fault	1. Improper sequence of KSI, power enable, and throttle inputs. 2. Misadjusted throttle pot.
2,3	PROC/WIRING FAULT	HPD fault present for >5 sec	1. Misadjusted throttle. 2. Broken throttle pot. 3. Broken throttle mechanism.
2,4	SPD LIMIT POT FAULT	speed limit pot fault	1. Speed limit pot wiper wire broken. 2. Broken speed limit pot.
3,1	BB WIRING CHECK	emerg. reverse wiring fault	1. BB wire open. 2. BB check wire open.
3,2	EM BRAKE DRVR FAULT	electromag. brake driver fault	1. Electromagnetic brake coil shorted or open. 2. Electromagnetic brake wiring open.
3,3	THROTTLE FAULT 1	throttle fault	1. Throttle input wire open. 2. Throttle input wire shorted to B- or B+. 3. Throttle pot defective. 4. Wrong throttle type selected.
4,1	LOW BATTERY VOLTAGE	low battery voltage	1. Battery voltage <16 volts (24V models), <21V (36V models), or <27V (48V models). 2. Corroded or loose battery terminal. 3. Loose controller terminal.
4,2	OVERVOLTAGE	overvoltage	1. Battery voltage >36 volts (24V models), >48V (36V models), or >60V (48V models). 2. Vehicle operating with charger attached.
4,3	THERMAL CUTBACK	over-/under-temp. cutback	1. Temperature >95°C or < -25°C. 2. Excessive load on vehicle. 3. Improper mounting of controller. 4. Operation in extreme environments.

## LED DIAGNOSTICS

During normal operation, with no faults present, the Status LED is steadily on. If the controller detects a fault, the Status LED provides two types of information. First, it displays a slow flash (2 Hz) or a fast flash (4 Hz) to indicate the severity of the fault. Slow-flash faults are self-clearing; as soon as the fault is corrected, the vehicle will operate normally. Fast-flash faults (“\*” in Table 9) are considered to be more serious in nature and require that the keyswitch (or power enable switch, if one is used) be cycled to resume operation after the fault is corrected.

Then, after the severity indication has been active for 5 seconds, the Status LED flashes a 2-digit fault identification code continuously until the fault is corrected. For example, code “4,1”—low battery voltage—appears as:

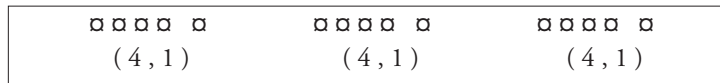

The codes are listed in Table 9.

<b>Table 9 STATUS LED FAULT CODES</b>			
LED CODES		EXPLANATION	
	<i>LED off</i>		no power or defective controller
	<i>solid on</i>		controller operational; no faults
*	1,1	□ □	output fault or overcurrent fault
*	1,2	□ □ □	EEPROM, main contactor, precharge, or motor voltage fault
	1,3	□ □ □ □	[not used]
	1,4	□ □ □ □ □	[not used]
	2,1	□ □ □	static return to off (SRO) fault
	2,2	□ □ □ □	high pedal disable (HPD) fault
*	2,3	□ □ □ □ □	HPD latching (HPD fault for >5 sec)
	2,4	□ □ □ □ □ □	speed limit pot fault
	3,1	□ □ □ □ □	emerg. rev. wiring fault (BB wiring check)
	3,2	□ □ □ □ □ □	electromagnetic brake driver fault
	3,3	□ □ □ □ □ □ □	throttle fault
	3,4	□ □ □ □ □ □ □ □	[not used]
	4,1	□ □ □ □ □ □	battery undervoltage
	4,2	□ □ □ □ □ □ □	battery overvoltage
	4,3	□ □ □ □ □ □ □ □	thermal cutback, due to over/under temp
	4,4	□ □ □ □ □ □ □ □ □	[not used]
* = “Fast-flash” fault—must cycle keyswitch or power enable switch to clear.			

NOTE: Only one fault is indicated at a time, and faults are not queued up.



Refer to the troubleshooting chart (Table 8) for suggestions about possible causes of the various faults.

### **SPEED LIMIT POT FAULT**

The controller will not display a fault if there is a problem with the speed limit pot or its wiring. However, if the speed limit pot is broken or if any of its wires is open, the vehicle drive speed will be limited to the specified minimum speed in the selected mode. Open circuit faults can be verified by observing the speed limit pot display in the Test Menu of the handheld programmer as this pot is adjusted. If the speed limit pot display does not change as the pot is adjusted, there is a problem with the pot wiring or the pot itself.

## 8

## MAINTENANCE

There are no user serviceable parts in the Curtis 1223/33, 1225/35, and 1227/37 controllers. **No attempt should be made to open, repair, or otherwise modify the controller.** Doing so may damage the controller and will void the warranty. However, it is recommended that the controller be kept **clean and dry** that its diagnostics history file be checked and cleared periodically.

## CLEANING

1223/33 Controllers

The 1223/33 controllers do not have covers. Because there are exposed components on the circuit board, no cleaning is recommended. Instead, the controller should be shielded from dirt and contaminants.

1225/35 and 1227/37 Controllers

The 1225/35 and 1227/37 controllers are covered units. It is recommended that the controller exterior be cleaned periodically (see procedure below).

**CAUTION**

**When working around any battery powered vehicle, proper safety precautions should be taken.** These include, but are not limited to: proper training, wearing eye protection, and avoiding loose clothing and jewelry.

Use the following cleaning procedure for routine maintenance.

1. Remove power by disconnecting the battery.
2. Discharge the capacitors in the controller by connecting a load (such as a contactor coil or a horn) across the controller's B+ and B- terminals.
3. Remove any dirt or corrosion from the connector area. The controller should be wiped clean with a moist rag. Dry it before reconnecting the battery.
4. Make sure the connections are tight.

## DIAGNOSTIC HISTORY

The handheld programmer can be used to access the controller's diagnostic history file. Connect the programmer, press the **[MORE INFO]** key, and then—while continuing to hold the **[MORE INFO]** key—press the **[DIAGNOSTICS]** key. The programmer will read out all the faults that the controller has experienced since the last time the

diagnostic history file was cleared. The faults may be intermittent faults, faults caused by loose wires, or faults caused by operator errors. Faults such as contactor faults may be the result of loose wires; contactor wiring should be carefully checked out. Faults such as HPD or overtemperature may be caused by operator habits or by overloading.

After a problem has been diagnosed and corrected, clearing the diagnostic history file is advisable. This allows the controller to accumulate a new file of faults. By checking the new diagnostic history file at a later date, you can readily determine whether the problem was indeed completely fixed.

To clear the diagnostic history file, go to the Special Program Menu (by pressing and holding the **[MORE INFO]** key, and then pressing the **[PROGRAM]** key), scroll through the menu until “Clear Diagnostic History” is the top line in the display, and then press **[MORE INFO]** again. The programmer will prompt you to acknowledge or cancel.

See Section 7 of this manual for more detail on 1307 handheld programmer operation.

**Note:** If you are using a newer programmer model, the fault history file is accessed through the Faults menu.



# APPENDIX A

## GLOSSARY OF FEATURES AND FUNCTIONS

### **Acceleration rate**

The acceleration rate is the time required for the controller to increase from 0 to 100% duty factor. The acceleration curve is controlled by the dynamic throttle response, which is linear. The acceleration rate is programmable—*see Section 3, page 29.*

### **Access rights**

Each programmable parameter is assigned an access level—OEM or User—that defines who is allowed to change that parameter. These levels are assigned by the OEM when the controller is originally specified. Restricting parameter access to the OEM reduces the likelihood of important performance characteristics being changed by someone unfamiliar with the vehicle's operation. In some cases, it may be necessary to restrict a parameter's access to ensure that it is not set to a value in violation of TÜV regulations. The 1307-1101 User programmer can adjust only those parameters with User access. The 1307-2101 OEM programmer can adjust all the programmable parameters. Typically, OEMs supply 1307-1101 programmers to their dealers and distributors so that the User-access parameters (for example, minimum speed and acceleration rate) can be set to each customer's liking in the store.

### **Anti-rollback**

The anti-rollback feature prevents a vehicle that is traveling uphill in forward or reverse from rolling back downhill when the throttle is released. It overrides the brake delay and engages the electromagnetic brake as soon as the vehicle begins to roll back down the incline.

### **Anti-roll-forward**

The anti-roll-forward feature prevents a vehicle that is traveling downhill in forward or reverse from rolling downhill excessively when the throttle is released. It modifies the brake delay time proportional to the estimated speed at the time the neutral throttle request is detected. This reduces “coasting” downhill when the throttle is released during low speed operation.

**Auxiliary driver: “Program 1”**

The program 1 driver is a short-circuit-protected low side driver capable of driving a 1 ampere load to B-. The program 1 driver is programmable and can be configured to drive an electromagnetic brake, hourmeter, brakelight, or sweeper/scrubber brush motor contactor—see *Section 3, page 41*.

**Auxiliary driver: “Program 2”**

The program 2 driver is available only on 123X controllers (1233/1235/1237). It is a high side driver capable of driving a 2 ampere load to B+, and is **not** short circuit protected. The program 2 driver is programmable and be configured to drive an hourmeter, brakelight, belly button check output, or sweeper/scrubber brush motor contactor—see *Section 3, page 42*.

**BB** (= *Belly Button; see Emergency reverse*)

**Brake delay time**

The brake delay time specifies when the controller engages the electromagnetic brake after the throttle is returned to neutral. This time delay, factory-specified for a throttle change from 100% to 0% duty factor, is set to be long enough to allow full deceleration without jerking the vehicle to a stop yet short enough so that the brake is engaged immediately after the vehicle comes to a stop.

The anti-rollback and anti-roll-forward features override the brake delay to prevent excessive travel on inclines when the throttle is released to neutral.

**Brake holding voltage**

This feature provides greater vehicle range and minimizes brake coil heating by reducing the power provided to the electromagnetic brake coil during operation. The brake holding voltage (“Program 4” in the Program Menu) is programmable—see *Section 3, page 43*.

**Creep speed at first throttle**

Creep speed, which is activated when the throttle is rotated out of the throttle deadband, helps to prevent rollback when starting uphill on an incline with low throttle. The creep speed parameter is programmable—see *Section 3, page 32*.

### **Current limiting**

Curtis controllers limit the motor current to a preset maximum. This feature protects the controller from damage that might result if the current were limited only by motor demand. PWM output to the power section is reduced until the motor current falls below the set limit level.

In addition to protecting the controller, the current limit feature also protects the rest of the system. By eliminating high current surges during vehicle acceleration, stress on the motor and batteries is reduced and their efficiency enhanced. Similarly, there is less wear and tear on the vehicle drivetrain, as well as on the ground on which the vehicle rides (an important consideration with golf courses and tennis courts, for example).

The current limit is programmable—*see Section 3, page 40.*

### **Current multiplication**

During acceleration and during reduced speed operation, the Curtis controller allows more current to flow into the motor than flows out of the battery. The controller acts like a dc transformer, taking in low current and high voltage (the full battery voltage) and putting out high current and low voltage. The battery needs to supply only a fraction of the current that would be required if a resistive controller were used. The current multiplication feature gives vehicles using Curtis controllers dramatically greater driving range per battery charge.

### **Deceleration rate**

The deceleration rate is the time required for the controller to decrease from 100% duty factor to zero. The deceleration rate and reverse deceleration rate can be defined separately. The deceleration rate controls how quickly the vehicle slows to a stop when it is moving forward. The reverse deceleration rate controls how quickly the vehicle slows to a stop when it is moving in reverse. The two deceleration rates are independent because it may be desirable to define a faster deceleration rate in the reverse direction.

The deceleration curve is controlled by the dynamic throttle response, which is linear. The deceleration rates are programmable—*see Section 3, page 29.*

### **Emergency reverse**

The emergency reverse feature is available only on 123X controllers (1233/1235/1237). Emergency reverse is activated when the keyswitch is On and the emergency reverse switch (the BB, or “belly button” switch) is pressed. After the BB switch is released, normal controller operation is not resumed until zero throttle is selected.

However, repeatedly pressing the BB switch will reactivate the emergency reverse function each time. The emergency reverse speed and current limit are both programmable—see *Section 3, page 32 (speed) and page 40 (current limit)*.

### **ET-series electronic throttles**

The ET-XXX is a wigwag-style throttle control assembly. It provides a 0–5V signal in both the forward and reverse directions. Use of this throttle control assembly requires that the controller throttle input be configured as single-ended, with a separate direction switch.

### **Fault detection and response**

An internal microcontroller automatically maintains surveillance over the functioning of the controller. When a fault is detected, the appropriate fault code is signalled via the Status LED and is also displayed on the handheld programmer via the Diagnostics Menu. See *Section 7, Diagnostics and Troubleshooting*.

The controller responds to overvoltage, undervoltage, thermal cutback, and emergency reverse wiring faults by reducing output. All other faults cause a complete shutdown of the motor drive.

The automatic fault detection system includes:

- current limit fault
- EEPROM fault
- emergency reverse wiring fault
- electromagnetic brake driver fault
- high pedal disable (HPD) fault
- main contactor fault
- memory checks upon start-up
- motor voltage fault
- output section fault
- overtemperature
- overvoltage
- precharge fault
- procedural/wiring fault (HPD fault >5 sec)
- static return to off (SRO) fault
- throttle fault
- undertemperature
- undervoltage
- watchdog (external)
- watchdog (internal).



## Fault recording

Fault events are recorded in the controller's memory. Multiple occurrences of the same fault are recorded as one occurrence.

The fault event list can be loaded into the programmer for readout. The Special Diagnostics mode provides access to the controller's diagnostic history file—the entire fault event list created since the diagnostic history file was last cleared. The Diagnostics mode, on the other hand, provides information about only the currently active faults.

## Fault recovery (including recovery from disable)

Almost all faults require a cycling of the keyswitch (or power enable switch, if used) to reset the controller and enable operation. The only exceptions are these:

FAULT	RECOVERY
BB wiring	clears when fault is corrected-
HPD	lower throttle to below HPD threshold
overvoltage	when battery voltage drops below overvoltage
SRO	when proper sequence is followed
thermal cutback	when temperature changes
throttle fault	clears when condition is gone
undervoltage	when battery voltage rises above undervoltage
<i>(all other faults)</i>	<i>(cycle keyswitch or power enable switch)</i>

## Full bridge

The 1223/33, 1225/35, 1227/37 controllers use a full bridge design for power switching and direction selection. This eliminates the need for external or on-board forward/reverse contactors. The result is a higher reliability product that is simpler to install.

## High-pedal-disable (HPD)

The HPD feature prevents controller output if the controller is turned on when the throttle is not in neutral. If the operator attempts to start the vehicle when the throttle is already applied, the controller output will remain off. For the vehicle to start, the controller must receive an input to KSI before receiving a throttle input. In addition to providing routine smooth starts, HPD also protects against accidental sudden starts if problems in the throttle linkage (e.g., bent parts, broken return spring) give a throttle input signal to the controller even with the throttle released. The HPD feature can be programmed On or Off—see *Section 3, page 43*. HPD must be set to On to meet TÜV regulations.

**HPD lockout (procedural/wiring fault)**

After 5 seconds of a continuous HPD fault, driving is inhibited until power to the controller is cycled. This feature prevents operation of a vehicle with a defective or misadjusted throttle.

**Inhibit**

The inhibit input is used to put the vehicle in a safe, non-drivable state during battery charging or under other conditions where this precaution is desired—*see Section 2, page 25.*

**IR compensation**

IR compensation is a technique used to provide near-constant speed control of the vehicle during varying motor loads despite resistive motor losses (IR). Internal circuitry monitors the current and voltage in the motor relative to throttle position and adjusts the controller output to maintain as constant a speed as possible during varying motor loads. The motor load varies as a function of inclines/declines in terrain or when the vehicle encounters an obstacle, such as debris on the sidewalk. The programmable IR speed coefficient parameter adjusts how aggressively the controller tries to maintain constant speed under changing load conditions—*see Section 3, page 44.*

**ISO pot fault**

All 1223/33, 1225/35, and 1227/37 controllers contain throttle pot fault circuitry that meets ISO 7176 requirements.

**Key off deceleration**

The key off deceleration feature provides controlled deceleration—rather than an abrupt stop—when the keyswitch is turned off for any reason while driving.

**KSI**

KSI (Key Switch Input) provides power to the controller's logic board, initializes the microprocessor, and starts diagnostics. If both a keyswitch and a power enable switch are used, the keyswitch will provide power to the controller's logic but the power enable switch must also be activated in order to drive the vehicle. The keyswitch functions as a master switch for the vehicle, to turn the system off when not in use.

**LEDs**

The 1223/33, 1225/35, and 1227/37 controllers allow for the use of Light Emitting Diodes (LEDs) to show the condition of certain switches and to provide system fault information—see *Section 2, page 25*.

**Load compensation** (*see IR compensation*)**Missing brake detection**

If the electromagnetic brake coil circuit is open, the controller inhibits driving and shorts the motor. If a mechanical brake release lever is used, it is recommended that a switch operated by this lever be wired in series with the brake coil to inhibit driving when the brake is mechanically released, as shown in the wiring diagrams. This provides a safety feature by ensuring the vehicle cannot be driven when the brake cannot be engaged. A brake coil disable switch or a self-resetting brake is required by TÜV regulations.

**Momentary switch input**

A control input configured for a momentary switch changes its state each time it receives a B+ signal. If the B+ signal is removed, the control function remains latched. For example, if the Mode input is configured for a momentary switch and the controller is in Mode 1, activating the switch momentarily (applying B+) puts the controller into Mode 2. The controller will remain in Mode 2 until another B+ signal is received. When the switch is again momentarily activated (B+ again applied to the Mode input) the controller will transition back to Mode 1 operation. Membrane switches built into a control pad are usually used with momentary control inputs.

**MOSFET**

A MOSFET (metal oxide semiconductor field effect transistor) is a type of transistor characterized by its fast switching speeds and very low losses.

**Motor voltage fault**

The motor voltage fault check circuit verifies that the average voltage being applied to the motor corresponds to that commanded by the throttle input. If there is a discrepancy between the throttle request and voltage across the motor, the controller is shut down. The motor voltage fault check is mandated by TÜV requirements.

**MultiMode™**

The MultiMode™ feature of these controllers allows the vehicle to be operated with two distinct sets of characteristics. The two modes can be programmed to be suitable for operation under different conditions, such as slow precise indoor maneuvering in Mode 1 and faster, long distance, outdoor travel in Mode 2. The following parameters can be set independently in the two modes:

- main current limit
- maximum speed
- minimum speed
- acceleration rate
- deceleration rate
- reverse deceleration rate
- IR speed compensation.

**OEM (= Original Equipment Manufacturer)****On/Off switch input**

A control input configured for an on/off switch is in a specific state depending on its applied voltage. For example, if the mode input is configured for an on/off switch, turning the switch on (applying B+) puts the controller into Mode 2. The controller will remain in Mode 2 as long as the switch is On and is therefore applying B+ to the mode input. When the mode switch is turned off (and B- is applied to the mode input) the controller will transition to Mode 1 operation. SPST toggle switches are usually used with on/off control inputs.

**Overtemperature** (*see Thermal protection*)**Overvoltage protection**

The overvoltage protection feature shuts down the regenerative current path to the controller if the voltage exceeds the factory-set limit. Controller operation resumes when the voltage is brought within the acceptable range. The cutoff voltage and re-enable voltage are percentages of the battery voltage, and are set at the factory. The controller can be configured to short the motor (required to meet TÜV regulations) or to let it coast in the event of overvoltage—*see Section 4, page 46*.

**Power saver**

The power saver feature minimizes battery power drain if the vehicle is left on but is not being used. The main contactor is released after 25 seconds if no throttle

commands are received. Normal operation resumes when the throttle is moved. If the throttle remains at neutral for 25 minutes, the controller powers down completely; normal operation resumes when the keyswitch (or power enable switch, if used) is cycled.

### **Precharge**

The precharge feature soft-charges the controller's internal capacitor bank when the controller is first turned on and before the main relay is engaged. This protects the main relay's contacts from the large inrush currents that exist when battery voltage is applied to a discharged capacitor bank.

### **Precharge fault**

The precharge fault feature keeps the main contactor from being engaged if the internal capacitor bank voltage does not rise above the minimum threshold within 500 ms after the controller is turned on. This protects the system against faults that short the controller's internal B+ bus.

### **Procedural/wiring fault (HPD lockout)**

After 5 seconds of a continuous HPD fault, driving is inhibited until power to the controller is cycled. This feature prevents operation of a vehicle with a defective or misadjusted throttle.

### **Push**

The push feature allows the brake to be released electrically so that the vehicle can be pushed. This is convenient when, for example, it is appropriate for an attendant to manually push a mobility aid scooter. The push feature inhibits the controller's drive function until the push switch is turned off, thus ensuring that the vehicle cannot be operated in a condition in which the electromagnetic brake cannot be engaged. To use the push feature, the batteries must be wired to the controller, the keyswitch must be enabled, the vehicle must be stopped, and the electromagnetic brake must be engaged.

If the vehicle is pushed too fast, indicating a runaway or other abnormal condition, the controller will automatically turn on and limit the speed of the vehicle (*see Push-too-fast, below*).

### **Push-too-fast**

The push-too-fast feature limits the maximum speed at which the vehicle can be pushed, thus guarding against unpowered vehicle runaway with the electro-

magnetic brake mechanically released. The controller, even if it is powered off and there are no batteries in the system, will detect the motor voltage created by the moving vehicle. When this voltage becomes high enough, indicating that significant vehicle speed has been reached, the controller logic will power up and turn on the MOSFET power sections to short the motor and limit the speed of the vehicle.

## **PWM**

Pulse width modulation (PWM), also called “chopping,” is a technique that switches battery voltage to the motor on and off very quickly, thereby controlling the speed of the motor. Curtis 1200 series controllers use high frequency PWM—15 kHz—which permits silent, efficient operation.

## **Ramp shape (static throttle map)**

The ramp shape parameter determines the controller’s static throttle map. Adjusting the throttle characteristics to suit your specific application can enhance your vehicle’s performance. The ramp shape parameter is programmable—*see Section 3, page 38*.

## **Regenerative braking**

The 1223/33, 1225/35, 1227/37 controllers use regenerative braking to slow the vehicle to a stop and to reduce speed when traveling downhill. Regenerative braking means that the energy used to slow the vehicle is channeled back into the batteries, resulting in longer vehicle range between charges.

## **Regen current boost**

By allowing the regenerative braking current to be set up to 25% higher than the main drive current limit, this feature can provide the higher braking torque necessary to stop very heavy vehicles on steep inclines. The regen current boost parameter (“Calibration 5” in the Program Menu) is programmable—*see Section 3, page 40*.

## **Reverse polarity protection**

If the B+ and B- connections are reversed to an otherwise properly wired controller, it will not allow the main contactor to be engaged. This protects the power MOSFET output section from being damaged by the reverse polarity.

### **Smooth, stepless operation**

Like all Curtis 1200 Series controllers, 1223/33, 1225/35, 1227/37 models allow superior operator control of the vehicle's drive motor speed. The amount of current delivered to the motor is set by varying the "on" time (duty cycle) of the controller's power MOSFET transistors. This technique—pulse width modulation (PWM)—permits silent, stepless operation.

### **Speed interlocks**

The 1223/33, 1225/35, and 1227/37 controllers come standard with speed interlocks. The speed interlocks prevent the speed parameters from being inadvertently programmed to give abnormal operating characteristics. The speed interlocks can be disabled at the factory, if so desired—*see Section 4, page 45*. However, this is not recommended unless a specific application requires that the existing speed interlock relationships be violated.

### **Speed settings**

There are two upper-limit speed settings in each mode: "maximum" and "minimum." The "maximum speed" setting defines the highest controller output at full throttle with the speed limit pot in its maximum speed position. The "minimum speed" setting defines the highest controller output at full throttle with the speed limit pot in its minimum speed position. The "maximum" and "minimum" speeds are programmable independently for Mode 1 and Mode 2—*see Section 3, page 30*.

### **Static-return-to-off (SRO)**

The SRO feature prevents the vehicle from being started when "in gear." SRO checks the sequencing of KSI (and power enable input, if a power enable switch is used) relative to either direction (Type 1) or relative to forward only (Type 2). The controller can be programmed to provide Type 0 (no SRO), Type 1 SRO, or Type 2 SRO—*see Section 3, page 43*.

### **Temperature compensation**

The 1223/33, 1225/35, 1227/37 controllers are specified to operate at their temperature-compensated current limits for one full minute. They employ temperature compensation to maintain consistent current limit and IR compensation levels. This minimizes performance variation resulting from changes in controller or ambient temperatures. There is, however, a small rolloff in the current limit

value as the controller's power section heats up. Variations of up to 10% of the specified 1-minute current limit rating may be observed in applications where the controller undergoes significant heating. Attention to controller heatsinking will minimize this effect.

### **Temperature data**

The temperature displayed in the 1307 programmer's Test Menu is the instantaneous heatsink temperature at that moment, in degrees Celsius.

### **Thermal protection**

Because of their efficiency and thermal design, Curtis controllers should barely get warm in normal operation. Overheating can occur, however, if the controller is undersized for its application or otherwise overloaded. If the internal temperature of the controller exceeds 90°C (194°F), the main current limit decreases steadily until it is reduced to zero at 105°C (221°F). At the reduced performance level, the vehicle can be maneuvered out of the way and parked. **NOTE:** To prevent loss of braking effort, regenerative current limit is not cut back in overtemperature conditions.

Full current limit and performance return automatically after the controller cools down. Although this action is usually not damaging to the controller\*, it does suggest a mismatch. If thermal cutback occurs often in normal vehicle operation, the controller is probably undersized for the application and a higher current model should be used.

The controller is similarly protected from undertemperature. Should its internal temperature fall below -25°C (-13°F), the current limit decreases to approximately one-half of the set current. When the controller warms up, full current limit and performance return automatically.

### **Throttle deadband (neutral deadband)**

The throttle deadband is the pot wiper voltage range that the controller interprets as neutral. The throttle deadband is typically set at 8%. A higher setting increases the neutral range, which can be useful with throttle assemblies that do not return reliably to a well-defined neutral point. The throttle deadband parameter is programmable—*see Section 3, page 36*.

---

\* Because braking current does not roll off in overtemperature, motor braking down a steep slope with a heavy load for an extended period could cause overheating of the MOSFETs.



## Throttle fault protection

### 5k $\Omega$ , 3-wire potentiometer throttle

For 5k $\Omega$ , 3-wire potentiometer throttles, the throttle fault detection circuitry meets ISO 7176 requirements. Also, throttle pot resistances outside the range of 4.5–7.5 k $\Omega$  are considered to be indicative of a faulty pot or faulty wiring, in which case the controller will register a pot fault. Fault detection causes the controller to decelerate to zero output. The controller returns to normal operation when the fault has been repaired.

### 0–5V throttle

Because the throttle input voltage is referenced to B- and no connection is made to the pot high and pot low inputs, complete throttle pot protection is lost with 0–5V throttles. Only a broken wire fault to the pot wiper input will be detected by the controller. Therefore, **it is the responsibility of the vehicle manufacturer to provide throttle fault detection for 0–5V throttles.**

**Throttle gain** (*see Throttle: restricted range*)

## Throttle map

The static throttle map (duty factor as a function of throttle position) is adjustable, in order to provide the proper feel for the many types of vehicles that use the 1223/33, 1225/35, and 1227/37 controllers. The throttle map parameter is called “ramp shape,” and is programmable—*see Section 3, page 38.*

## Throttle response

The dynamic throttle response (duty factor as a function of time) is shaped by the acceleration and deceleration rate settings. Dynamic throttle response is linear. The newest throttle input is mapped to the throttle map, and the controller then automatically accelerates (or decelerates) through a straight line until the new throttle demand is obtained.

## Throttle: restricted range

The 1223/33, 1225/35, and 1227/37 controllers can be programmed for use with restricted range throttle inputs via the throttle gain parameter—*see Section 3, page 37.* This capability allows throttle pots with less than 5k $\Omega$  total full stroke wiper resistance to be used.

### Throttle types

The controller can be programmed to accept wigwag or single-ended signals from a 5k $\Omega$ , 3-wire pot or from a 0–5V voltage source—see *Section 3, page 33*.

### Undertemperature *(see Thermal protection)*

### Undervoltage protection

Undervoltage protection automatically cuts back the controller output if battery voltage is detected below the undervoltage point at start-up, or when the battery voltage is pulled below the undervoltage point by an external load. The undervoltage cutback point is not adjustable.

During normal operation, the controller duty factor will be reduced when the batteries discharge down to less than the undervoltage level. If the motor current is such that the batteries are being pulled below the minimum point, the duty factor will be reduced until the battery voltage recovers to the minimum level. In this way the controller “servos” the duty factor around the point which maintains the minimum allowed battery voltage.

If the voltage continues to drop below the undervoltage level to a severe undervoltage condition (due to battery drain or external load), the controller continues to behave in a predictable fashion, with its output disabled.

### Watchdog (external, internal)

The external watchdog timer guards against a complete failure of the microprocessor, which would incapacitate the internal watchdog timer. This independent system check on the microprocessor meets the EEC’s requirement for backup fault detection.

The external watchdog timer safety circuit shuts down the controller (and the microprocessor) if the software fails to generate a periodic external pulse train. This pulse train can only be created if the microprocessor is operating. If not periodically reset, the watchdog timer times out after 15–20 msec and turns off the controller. The external watchdog also directly shuts down the PWM drive to the MOSFETs. It can only be reset by cycling KSI (or the power enable switch, if one is used).

The internal watchdog timer must be reset periodically by correct sequential execution of the software. If not reset, the internal timer times out and the microprocessor is “warm booted.” This causes the microprocessor to shut down its outputs—thus shutting down the controller—and attempt to restart.

## APPENDIX B THROTTLE MOUNTING DIMENSIONS

**Fig. B-1** Mounting dimensions,  
Curtis standard  
5kΩ, 3-wire throttle  
potentiometer,  
p/n 98191.

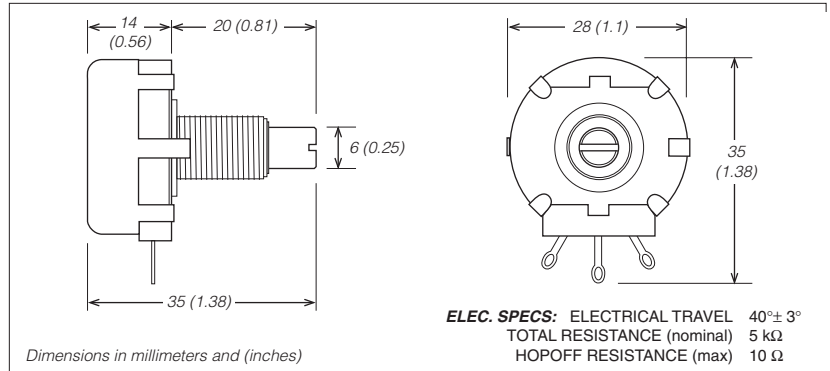

**Fig. B-2** Mounting dimensions,  
Curtis potboxes  
PB-5, -6, -9, and -10.

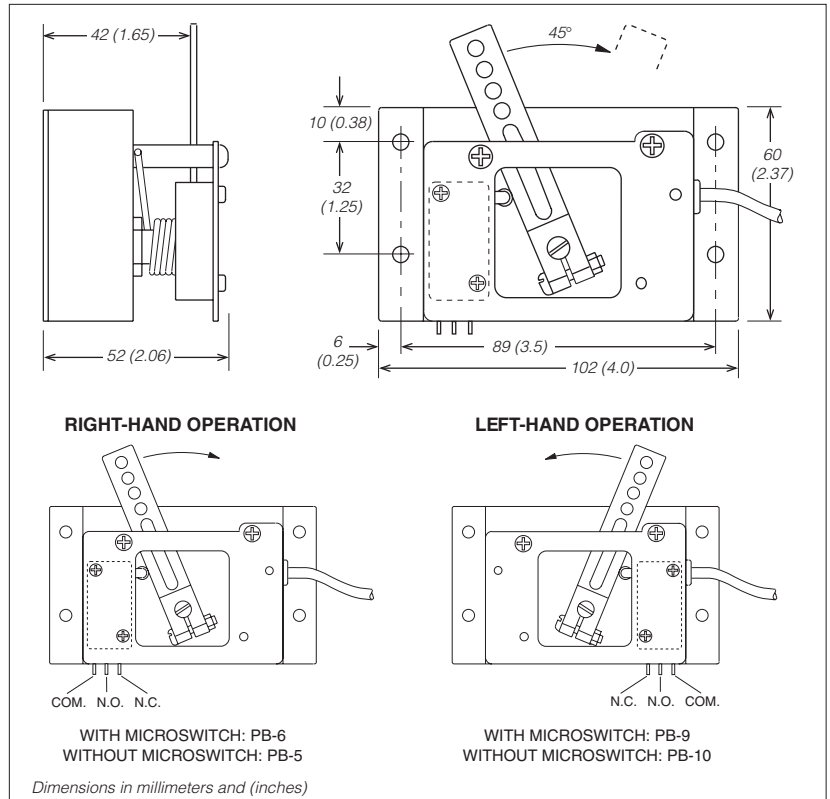

**Fig. B-3** *Curtis footpedal FP-2.*

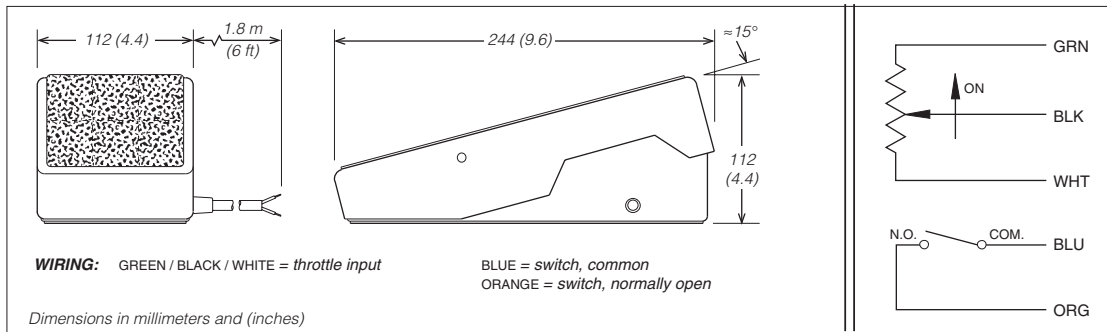

**Fig. B-4** *Mounting dimensions, Curtis electronic throttle (ET series).*

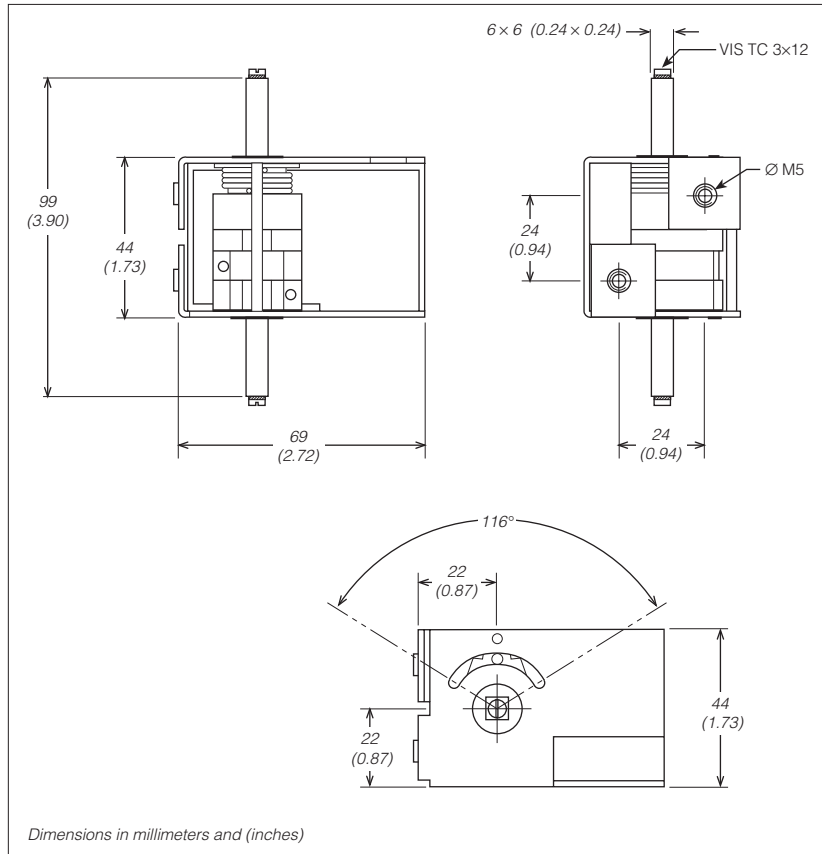

## APPENDIX B

### CURTIS WEEE / RoHS STATEMENT, MARCH 2009

#### WEEE

The Directive 2002/96/EC on Waste Electrical and Electronic Equipment (WEEE) was adopted by the European Council and Parliament and the Council of the European Union on January 27, 2003. The aim of the directive was to improve the collection and recycling of WEEE throughout the EU, and to reduce the level of non-recycled waste. The directive was implemented into law by many EU member states during 2005 and 2006. This document provides a general description of Curtis's approach to meeting the requirements of the WEEE legislation.

Note that the directive gave some flexibility to the member states in implementing their individual WEEE regulations, leading to the definition of varying implementation requirements by country. These requirements may involve considerations beyond those reflected in this document. This statement is not intended and shall not be interpreted or construed to be legal advice or to be legally binding on Curtis or any third party.

#### *Commitment*

Curtis is committed to a safe and healthy environment and has been working diligently to ensure its compliance with WEEE legislation. Curtis will comply with WEEE legislation by:

- Designing its equipment with consideration to future dismantling, recovery and recycling requirements;
- Marking its products that fall within the scope of the directive with the required symbol and informing users of their obligation;
- To separate WEEE from general waste and dispose of it through the provided recycling systems;
- Reporting information as required by each member state;
- Facilitating the collection, recycling and disposal of WEEE from private households and other than private households (businesses) as defined by the applicable member state regulation;
- Providing information to treatment centres according to the requirements defined in the local regulation.

#### *WEEE symbol on Curtis products*

The requirement to mark equipment with the WEEE symbol (the crossed-out wheeled bin) went into effect as of August 13, 2005. As of this date, Curtis Instruments began the process of marking all products that fall within scope of this directive with the WEEE symbol, as shown here.



### *Obligations for buyers of electrical and electronic equipment*

As of 13 August 2005, in each EU member state where the WEEE directive has been implemented, disposal of EEE waste other than in accordance with the scheme is prohibited. Generally, the schemes require collection and recycling of a broad range of EEE products. Certain Curtis products fall within the scope of the directive and the implemented member state regulations. Affected Curtis products that have reached end-of-life must not be disposed as general waste, but instead, put into the collection and recycling system provided in the relevant jurisdiction.

### **RoHS**

For several years now, Curtis has been implementing a rigorous program with the aim of achieving full compliance with the Restrictions on the use of Hazardous Substances (RoHS) Directive, 2002/95/EC.

Curtis has taken all available steps to eliminate the use of the six restricted hazardous substances listed in the directive wherever possible. As a result of the Curtis RoHS program, many of our instrumentation product lines are now fully RoHS compliant.

However, Curtis's electronic motor speed controller products are safety-critical devices, switching very large currents and designed for use in extreme environmental conditions. For these product lines, we have successfully eliminated five out of the six restricted hazardous substances. The single remaining issue preventing full RoHS compliance is the unsuitability of the lead-free solders available to date, due to the well-documented issues such as tin whiskers, and premature failure (compared with leaded solder) due to shock, vibration, and thermal cycling.

Curtis is closely monitoring all RoHS developments globally, and in particular is following the automotive industry's attempts to introduce lead-free solder as a result of the End of Life Vehicle (ELV) Directive, 2003/53/EC. To date, the automotive industry has rejected all lead-free solder pastes due to a significant reduction in reliability compared to leaded soldering.

Curtis firmly believes that the operating environments, safety requirements, and reliability levels required of automotive electronics are directly analogous to that of our speed controller products. As such, Curtis will not be switching to a lead-free solder process until lead-free solder pastes and techniques are available that meet the requirements of the RoHS study groups and ELV Automotive Industry bodies. That is, when all known issues, including that of tin whiskers, are satisfactorily resolved.

At this moment in time, all Curtis motor speed controllers used on industrial vehicle applications are also regarded as exempt under EEE category 9 of the RoHS directive 2002/95/EC. This means there is no requirement at this time for Curtis control systems used on such equipment to comply with the directive. Curtis will work closely with all key customers to ensure that whenever possible, we are in a position to continue the supply of products should these exemptions expire.

## APPENDIX D

### PROGRAMMING DEVICES

Curtis programmers provide programming, diagnostic, and test capabilities for the 1223/33, 1225/35, and 1227/37 controllers. The power for operating the programmer is supplied by the host controller via a 4-pin connector. When the programmer powers up, it gathers information from the controller.

Two types of programming devices are available: the 1314 PC Programming Station and the 1313 handheld programmer. The Programming Station has the advantage of a large, easily read screen; on the other hand, the handheld programmer (with its 45×60mm screen) has the advantage of being more portable and hence convenient for making adjustments in the field.

Both programmers are available in User, Service, Dealer, and OEM versions. Each programmer can perform the actions available at its own level and the levels below that—a User-access programmer can operate at only the User level, whereas an OEM programmer has full access.

#### PC PROGRAMMING STATION (1314)

The Programming Station is an MS-Windows 32-bit application that runs on a standard Windows PC. Instructions for using the Programming Station are included with the software.

#### HANDHELD PROGRAMMER (1313)

The 1313 handheld programmer is functionally equivalent to the PC Programming Station; operating instructions are provided in the 1313 manual. This programmer replaces the 1307 and 1311, earlier models with fewer functions.

#### PROGRAMMER FUNCTIONS

Programmer functions include:

**Parameter adjustment** — provides access to the individual programmable parameters.

**Monitoring** — presents real-time values during vehicle operation; these include all inputs and outputs.

**Diagnostics and troubleshooting** — presents diagnostic information, and also a means to clear the fault history file.

**Programming** — allows you to save/restore custom parameter settings files and also to update the system software (not available on the 1307 or 1311).

**Favorites** — allows you to create shortcuts to your frequently-used adjustable parameters and monitor variables (not available on the 1307 or 1311).

## APPENDIX E SPECIFICATIONS

**Table E-1 SPECIFICATIONS: 1223/33 CONTROLLERS**

Nominal input voltage	24 V and 36V
PWM operating frequency	15 kHz
Electrical isolation to heatsink	500 V ac (minimum)
KSI input current (typical)	100 mA without programmer; 150 mA with programmer
Logic input current (typical)	10 mA at 24 V
Auxiliary Driver 1 current	1 A (short circuit protected)
Auxiliary Driver 2 current	2 A (not short circuit protected)
Acceleration delay range	0.2 – 3.0 s
Deceleration delay range	0.2 – 3.0 s
Control input switch type	momentary or on/off
Speed control signal	3-wire, 0–5kΩ; or 0–5V
Speed control type	single-ended or wigwag
Operating ambient temperature range	-10°C to 45°C (14°F to 113°F)
Weight	0.33 kg (0.75 lb)
Dimensions (LxWxH)	104 x 146 x 39 mm (4.10" x 5.75" x 1.53")

MODEL NUMBER	NOMINAL BATTERY VOLTAGE (volts)	CURRENT LIMIT (amps)	*		VOLTAGE DROP @ 20 AMPS (volts)	UNDER-VOLTAGE CUTBACK (volts)
			1 MIN RATING (amps)	1 HOUR RATING (amps)		
1223-21XX	24	60	60	40	0.45	16
1223-24XX	24	90	90	40 †	0.30	16
1223-27XX	24	110	110	40 †	0.25	16
1223-31XX	36	45	45	30	0.45	21
1223-34XX	36	70	70	40	0.30	21
1233-21XX	24	60	60	40	0.45	16
1233-24XX	24	90	90	40 †	0.30	16
1233-27XX	24	110	110	40 †	0.25	16
1233-31XX	36	45	45	30	0.45	21
1233-34XX	36	70	70	40	0.30	21

NOTE: Current limit ratings based on a minimum 4" x 8" x 1/8" aluminum plate heatsink.

\* Actual value of 1-minute rating depends on MOSFET heating (see "Temperature compensation" in Appendix A: Glossary).

† Limited by rated main relay continuous current.



**Table E-2 SPECIFICATIONS: 1225/35 CONTROLLERS**

Nominal input voltage	24 V and 36 V
PWM operating frequency	15 kHz
Electrical isolation to heatsink	500 V ac (minimum)
KSI input current (typical)	100 mA without programmer; 150 mA with programmer
Logic input current (typical)	10 mA at 24 V
Auxiliary Driver 1 current	1 A (short circuit protected)
Auxiliary Driver 2 current	2 A (not short circuit protected)
Acceleration delay range	0.2 – 3.0 s
Deceleration delay range	0.2 – 3.0 s
Control input switch type	momentary or on/off
Speed control signal	3-wire, 0–5k $\Omega$ ; or 0–5V
Speed control type	single-ended or wigwag
Operating ambient temperature range	-10°C to 45°C (14°F to 113°F)
Weight	1.0 kg (2.2 lb)
Dimensions (LxWxH)	127 x 159 x 48 mm (5.00" x 6.25" x 1.88")

MODEL NUMBER	NOMINAL BATTERY VOLTAGE (volts)	CURRENT LIMIT (amps)	* 1 MIN RATING (amps)	1 HOUR RATING (amps)	VOLTAGE DROP @ 20 AMPS (volts)	UNDER-VOLTAGE CUTBACK (volts)
1225-21XX	24	65	65	50	0.45	16
1225-24XX	24	100	100	60	0.30	16
1225-27XX	24	125	125	70	0.25	16
1225-31XX	36	90	90	50	0.25	21
1235-21XX	24	65	65	50	0.45	16
1235-24XX	24	100	100	60	0.30	16
1235-27XX	24	125	125	70	0.25	16
1235-31XX	36	90	90	50	0.25	21

\* Actual value of 1-minute rating depends on MOSFET heating (see "Temperature compensation" in Appendix A: Glossary).

**Table E-3 SPECIFICATIONS: 1227/37 CONTROLLERS**

Nominal input voltage	24 V, 36 V, and 48 V
PWM operating frequency	15 kHz
Electrical isolation to heatsink	500 V ac (minimum)
KSI input current (typical)	100 mA without programmer; 150 mA with programmer
Logic input current (typical)	10 mA at 24 V
Auxiliary Driver 1 current	1 A (short circuit protected)
Auxiliary Driver 2 current	2 A (not short circuit protected)
Acceleration delay range	0.2 – 3.0 s
Deceleration delay range	0.2 – 3.0 s
Control input switch type	momentary or on/off
Speed control signal	3-wire, 0–5k $\Omega$ ; or 0–5V
Speed control type	single-ended or wigwag
Operating ambient temperature range	-10°C to 45°C (14°F to 113°F)
Weight	1.1 kg (2.5 lb)
Dimensions (LxWxH)	122 x 165 x 65 mm (4.80" x 6.50" x 2.56")

MODEL NUMBER	NOMINAL BATTERY VOLTAGE (volts)	CURRENT LIMIT (amps)	*		VOLTAGE DROP @ 20 AMPS (volts)	UNDER-VOLTAGE CUTBACK (volts)
			1 MIN RATING (amps)	1 HOUR RATING (amps)		
1227-21XX	24	150	150	60	0.16	16
1227-24XX	24	200	200	70	0.08	16
1227-27XX	24	250	250	100	0.04	16
1227-34XX	36	160	160	60	0.08	21
1227-41XX	48	100	100	40	0.15	27
1237-24XX	24	200	200	70	0.08	16
1237-34XX	36	160	160	60	0.08	21
1237-41XX	48	100	100	40	0.15	27

\* Actual value of 1-minute rating depends on MOSFET heating (see "Temperature compensation" in Appendix A: Glossary).