

## SOUNDER PLINTH

### MODEL 29

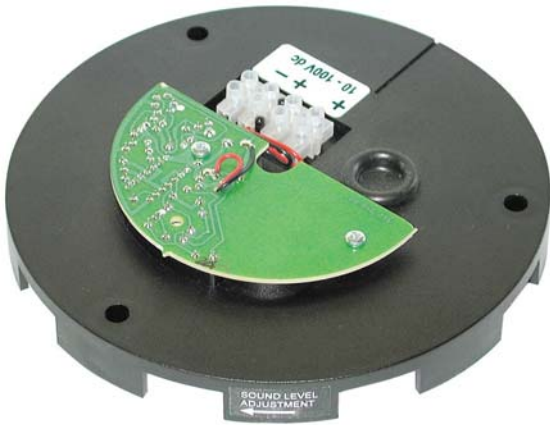

### *Application*

The Curtis Sounder Plinth is intended to work in conjunction with Curtis Instruments' range of Beacons. The Sounder Plinth is suitable for most applications, such as pallet trucks, airport equipment, IC engine and battery powered fork-lift trucks, construction plant, agricultural equipment, specialist road vehicles and industrial applications.

### *Features and Specifications*

The Curtis Sounder Plinth complies with the EMC Directive 89/336/EEC and the Low Voltage Directive 73/23/EEC, when correctly installed by a qualified electrician and fitted in conjunction with a Curtis Instruments Beacon.

## DESCRIPTION

*The Curtis Sounder Plinth is intended to provide a supplementary sound signal in conjunction with a Curtis Instruments Beacon and can be used as a 'back-up' alarm on fork-lift trucks.*

## WARRANTY

2-years from date of delivery.  
Subject to approved installation.

- Dimensions:  
*Height (under Beacon) 15mm  
149 Diameter x 25mm*
- Sound:  
*Adjustable 70-90dB @ 300mm  
1 beep per second*
- Power Supply  
*Nominal Voltage 12-80VDC  
Voltage Range 10-100VDC  
Nominal Current 10mA*
- Temperature Range:  
*-20 to 55°C*
- Connections:  
*4-way terminal block - 2 for strobe*

**UK Part Number : AA483-101**

### **CURTIS INSTRUMENTS (UK) LIMITED**

5 Upper Priory Street • Northampton • NN1 2PT • England  
Tel: +44 (0)1604 629755 • Fax: +44 (0)1604 629876  
www.curtisinst.co.uk • e-mail@curtisinst.co.uk

## Fitting Instructions

The Sounder Plinth and Beacon should be mounted on a flat part of the vehicle and fitted as shown in Fig 3.0. The power input cable must be two or three core insulated and sheathed and of adequate rating (0.5mm sq. 250V). The power supply should be fitted with a suitable fuse (for fuse rating see instructions with Beacon).

A hole of close fitting diameter should be pierced in the rubber grommet fitted in the Sounder Plinth and the cable passed through. Electrical connections are made as indicated in Fig 2.0. The Sounder Plinth will operate from a DC supply of 10 to 100V.

Before installing the Sounder Plinth the sound level may be adjusted by setting the position of the flap on the underside of the plinth to obscure the sound output hole (minimum output) or to fully expose the hole (maximum output) or an immediate position may be set.

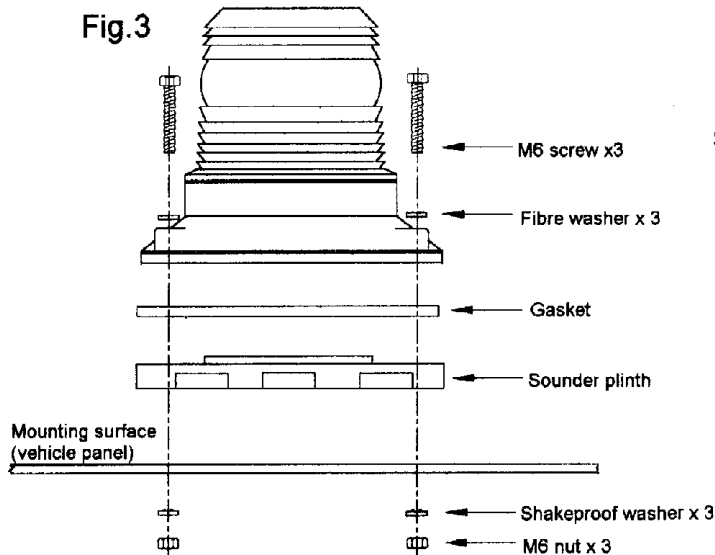
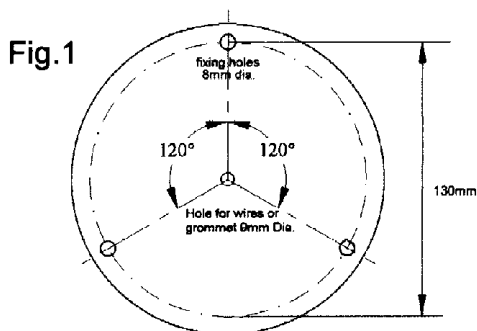

**Fig.2a**  
Sounder and beacon operating together

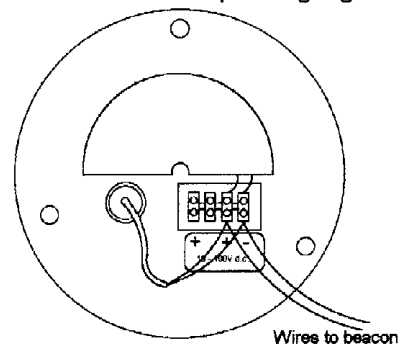

**Fig.2b**  
Sounder and beacon separately switchable

