

BEACONS

MULTI-VOLTAGE (SLIMLINE) LED BEACON



CURTIS



DESCRIPTION

Compact, multi-voltage general purpose LED beacon with low power consumption and high reliability.

APPLICATION

This beacon is suitable for a variety of industrial vehicles, such as floor care, aerial lift, ground support, lift trucks, off-road vehicles and industrial applications.

FEATURES

- High impact polycarbonate lens.
- Long life LEDs improve reliability and lower costs.
- 2 bolt fixing for standard units.
- Hexagonal base.
- 30 SMD LEDs.

SPECIFICATIONS

- Voltage Range: 12 to 80 VDC.
- Dimensions: 130 mm x 100 mm.
- Fixing: Standard 2 bolt fixing.
- Approvals: ECE R10 Approved.
- IP Rating: IP65.

UK PART NUMBER

18435371 — 12–80V LED Amber Beacon.

18435379 – 12-80v LED Green Beacon.

WARRANTY

Two year limited warranty from time of delivery.

DIMENSIONS mm

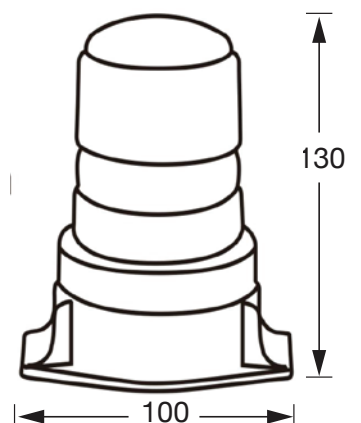

CURTIS INSTRUMENTS, (UK) LTD.
5 UPPER PRIORY STREET
NORTHAMPTON NN1 2PT, ENGLAND
TEL 44 (0) 1604-629755
FAX 44 (0) 1604-629876

www.curtisinst.co.uk • info@curtisinst.co.uk

