

# MULTI-VOLTAGE LED & XENON BEACONS



CURTIS

## MODEL SB SAFETY BEACONS



Hexagonal Base



Round Base

### FEATURES

- High impact polycarbonate lens and high performance ABS base ensure reliable operation in severe environments.
- Epoxy-potted electronics permits use in high moisture environments such as freezer applications.
- Wide voltage range (12-80 VDC) minimizes the number of models that need to be qualified, sourced and stocked, thereby lowering the total cost of ownership.
- Long life LEDs improve reliability and lower cost of ownership.
- Round base conforms to European and U.S. standard mounting dimensions. Only one model is needed to satisfy worldwide applications, thereby minimizing cost.
- Lens is easily replaceable so that equipment use time is maximized. On xenon versions, the tube is also replaceable.
- Low profile and compact design allows use in tight spaces.
- Mounting gasket (supplied with all units) protects panel area from moisture and debris thereby increasing product life.
- Also available with a red, green or blue lens.

### DESCRIPTION

High efficiency, compact, multi-voltage LED and xenon beacons. Very low power consumption and high reliability.

### APPLICATION

This beacon is suitable for a variety of industrial vehicles, such as floor care, aerial lift, ground support, lift trucks, off-road vehicles and industrial applications.



# MODEL SB SAFETY BEACONS

## SPECIFICATIONS

<b>Voltage Range</b>	12-80 VDC
<b>Flash Rate</b>	75 / min single flash
<b>Current Consumption</b>	0.5A @ 12V

<b>Operating Temperature</b>	-30°C to +50°C
<b>Environmental Protection</b>	IP54
<b>Lens</b>	Amber, red, green, blue.

## DIMENSIONS mm

Hexagonal Base

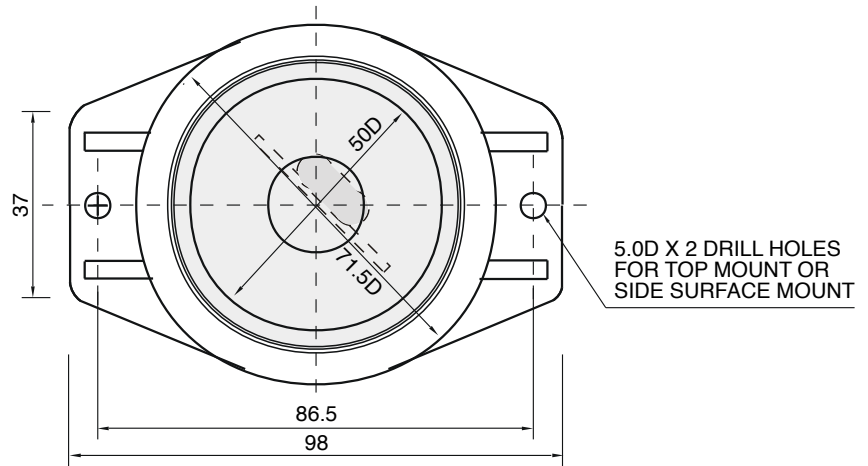

TOPVIEW

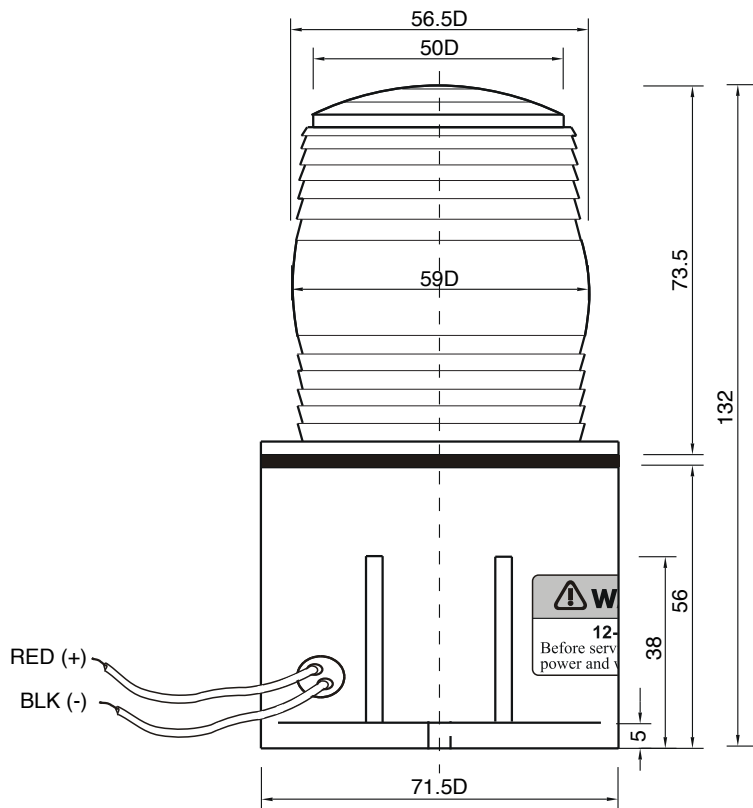

SIDE VIEW

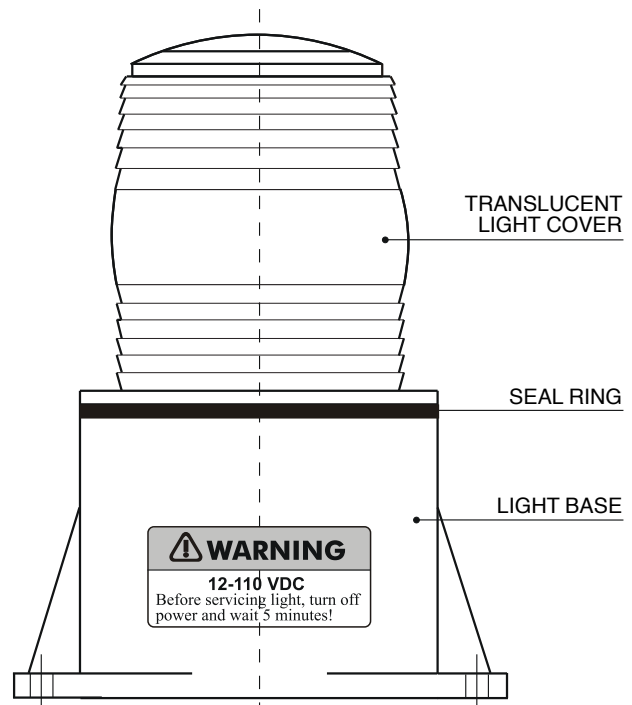

FRONT VIEW

# MODEL SB SAFETY BEACONS

## Round Base

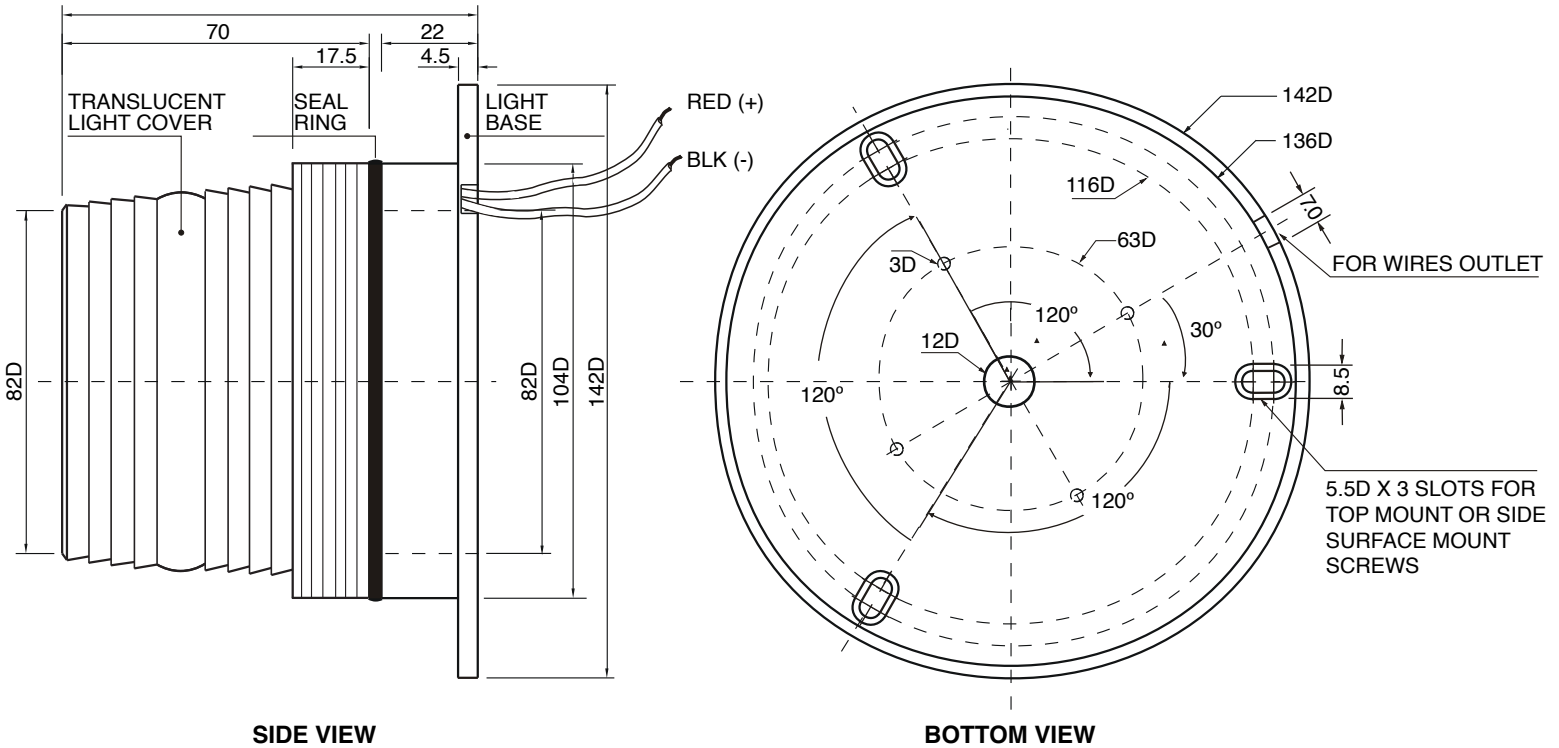

## OPTIONS

Base	Light Source	Curtis Part Number	Curtis Model Number
Round	Xenon	18133700-0001X	SBA-AP-0001X
Round	LED	18133900-0001X	SBL-AP-0001X
Hexagonal	Xenon	18133700-0002X	SBA-AP-0002X
Hexagonal	LED	18133900-0002X	SBL-AP-0002X

Accessories	Round Base	Hexagonal Base
Protective Cage	18133804-0001	18133804-002
Xenon Tube	18133802-0001	18133802-0002
Amber Lens	18133801-0001A	18133801-0002A
Blue Lens	18133801-0001B	18133801-0002B
Green Lens	18133801-0001G	18133801-0002G
Red Lens	18133801-0001R	18133801-0002R

*X=Lens Color  
B=Blue  
G=Green  
R=Red*

**WARRANTY** Two year limited warranty from time of delivery.

