

MULTI VOLTAGE LED SAFETY LAMP

RED SAFETY ZONE LAMP (12-60V)



DESCRIPTION

A 12–60V low power draw LED Spot lamp, on a single bolt fixing, featuring a narrow spreading beam of coloured light highlighting the presence of a nearby vehicle or machine.

APPLICATION

LED Safety Zone Spot Lamps are designed to provide a visual warning for pedestrians moving in the vicinity of materials handling equipment. The adjustable light projects a bright red line onto the floor, indicating a clear no-go-zone, ensuring pedestrians stay a safe distance away from equipment and vehicles.

FEATURES

- Very low footprint.
- LED technology with low power consumption.
- Small spot lamp projects a bright red line on the floor indicating a clear danger zone to keep pedestrians away.
- Aluminium housing with polycarbonate lens.
- Two year warranty.
- Mounting bracket supplied.

SPECIFICATIONS

- 12–60 VDC.
- IP67 rated.
- Weight: 250g.
- Estimated life span >30,000 hours.

QUALITY

Meets 2004/10/EC Directive.

Meets 2006/95/EC Directive.

Recognized per ECE R10 Regulation.

RoHs recognized.

CE recognized.

CURTIS INSTRUMENTS, (UK) LTD.
5 UPPER PRIORY STREET
NORTHAMPTON NN1 2PT, ENGLAND
TEL 44 (0) 1604-629755
FAX 44 (0) 1604-629876

RED SAFETY ZONE LAMP

MODEL CHART

P/N	MODEL	LUMINOUS FLUX lm	POWER W	VOLTAGE RANGE	CURRENT A	
					12V	60V
18438442	Red Safety Zone W/Lamp 12/60V	104	6	12-60 VDC	1 amp maximum	

DIMENSIONS

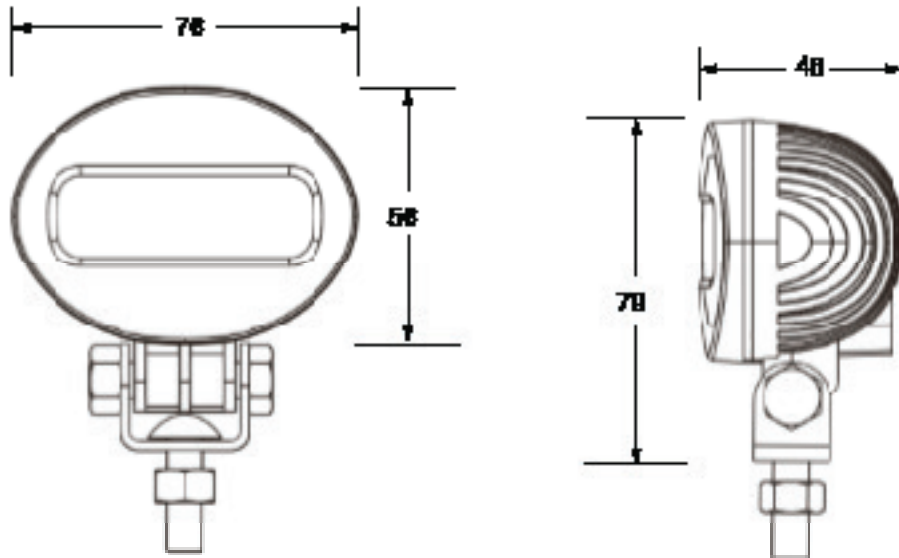

MOUNTING POSITION

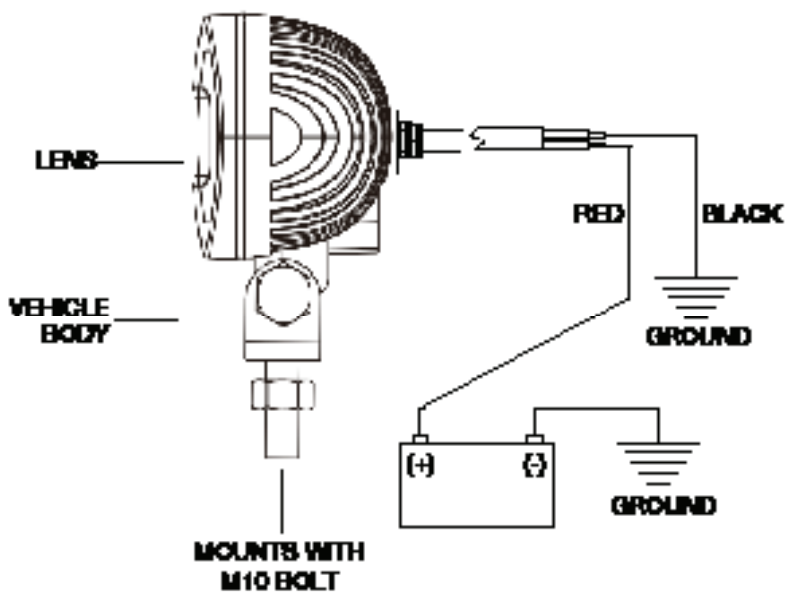

WARRANTY Two year limited warranty from time of delivery.

The Curtis Difference
You feel it when you drive it

