

BEACONS

MULTI-VOLTAGE LED BEACON



CURTIS



DESCRIPTION

Compact, multi-voltage general purpose LED beacon with low power consumption and high reliability.

APPLICATION

This beacon is suitable for a variety of industrial vehicles, such as floor care, aerial lift, ground support, lift trucks, off-road vehicles and industrial applications.

FEATURES

- Bright and effective quad mode flash.
- Long life LEDs improve reliability and lower costs.
- Reverse polarity protection.
- Universal 3 bolt fixing for standard units.
- 12 SMD LEDs.

SPECIFICATIONS

- Voltage Range: 12 to 80 VDC.
- Dimensions: 130mm x 95mm.
- Fixing: Standard 3 bolt fixing.
- Approvals: ECE R10 approved.
- IP Rating: IP65.

UK PART NUMBER

18435373 – 12-80V LED Amber Beacon.

CURTIS INSTRUMENTS, (UK) LTD.
5 UPPER PRIORY STREET
NORTHAMPTON NN1 2PT, ENGLAND
TEL 44 (0) 1604-629755
FAX 44 (0) 1604-629876

MULTI-VOLTAGE LED BEACON

DIMENSIONS mm

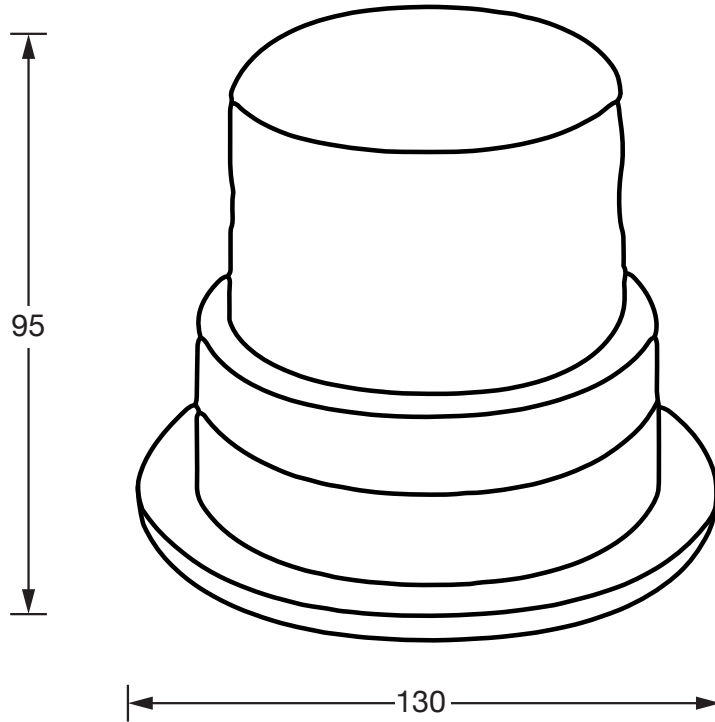

WARRANTY Two year limited warranty from time of delivery.