

LED BEACON



DESCRIPTION

A bright, six-flash burst, multi-voltage, amber LED beacon with reverse polarity protection. Steady burn (continuously on) option.

APPLICATION

This beacon is designed for use on all battery powered vehicle types throughout the materials handling market.

PART NUMBER

18133750-0001 – Beacon

WARRANTY

Two year limited warranty from time of delivery.

FEATURES

- Bright, intense "6 burst" LED flash.
- Flash rate 62 FPM.
- Multi-voltage, 10–100V DC, 20–72V AC (nominal).
- LED technology with low power consumption.
- Reverse polarity protection.
- Steady burn (on) option.

SPECIFICATIONS

- 120mm (H) x 148mm (D).
- 65 flashes per minute, or continuous "on".
- IP65 rated.
- Standard 3 bolt fixing.
- Certification: CE certified, EMC E11 10R-035715, RoHS compliant.
- Current Consumption 110mA @12V DC, 55mA @ 24V DC.
- Voltage: 110V DC maximum, 7V DC minimum
- Operating temperature –30°C to +55°C

DIMENSIONS mm

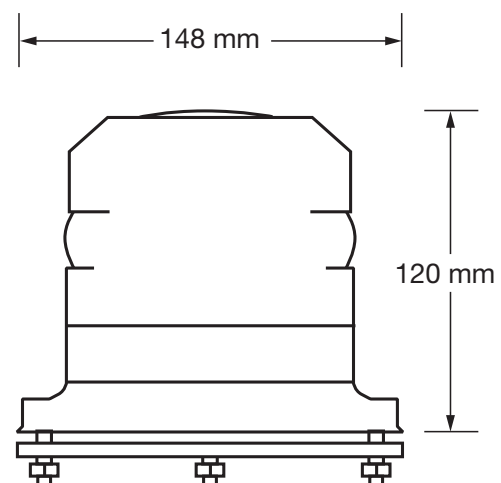

CURTIS INSTRUMENTS, (UK) LTD.
5 UPPER PRIORY STREET
NORTHAMPTON NN1 2PT, ENGLAND
TEL 44 (0) 1604-629755
FAX 44 (0) 1604-629876

www.curtisinst.co.uk • e-mail@curtisinst.co.uk