

## MULTI VOLTAGE LED SAFETY LAMP

### HALO SAFETY LAMP (12-80V)



#### DESCRIPTION

A 12-80V low power draw LED safety lamp, on a single bolt fixing, projecting a coloured "arc" of light around the front/rear of a forklift highlighting its presence to nearby pedestrians.

#### APPLICATION

Coloured LED Safety Lamps are designed to provide a visual warning for pedestrians moving in the vicinity of materials handling equipment. The adjustable light projects a bright red/blue/green arc of light onto the floor, indicating a clear no-go-zone, ensuring pedestrians stay a safe distance away from equipment and vehicles.

#### FEATURES

- LED technology with low power consumption and very long lifespan of 30,000 hours.
- Very compact.
- Aluminium housing with polycarbonate lens.
- Two year warranty.

#### SPECIFICATIONS

- 12-80 VDC.
- IP68 rated.
- Part Number: 18438480.
- Single bolt fixing/bracket.
- Operating temperature  $-45^{\circ}\text{C}$  -  $+85^{\circ}\text{C}$ .

#### QUALITY

Recognized per ECE R10 Regulation.

RoHs recognized.

CE recognized.

**CURTIS INSTRUMENTS, (UK) LTD.**  
5 UPPER PRIORY STREET  
NORTHAMPTON NN1 2PT, ENGLAND  
TEL 44 (0) 1604-629755  
FAX 44 (0) 1604-629876

# HALO SAFETY LAMP

## MODEL NUMBER

Part Number	Description	Power In W	Current Consumption	Maximum Current	
				12V	24V
184 38 480	HALO SECURITY ZONE 12/80 volt	5	10-110 Vcc	0.8	0.4

## DIMENSIONS mm

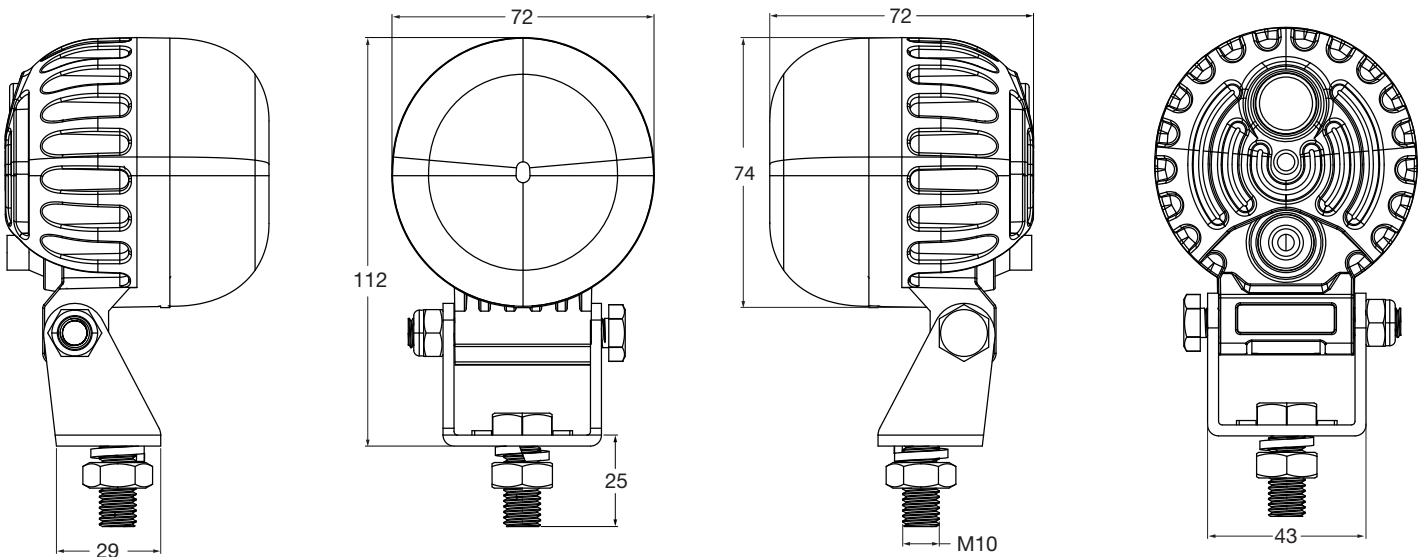

**WARRANTY** Two year limited warranty from time of delivery.



The Curtis Difference   
You feel it when you drive it

