

MULTI VOLTAGE LED SAFETY LAMP

HALO SAFETY LAMP (12-80V)



DESCRIPTION

A 12–80V low power draw LED safety lamp, on a single bolt fixing, projecting a coloured “arc” of light around the rear of a forklift highlighting its presence to nearby pedestrians.

APPLICATION

Coloured LED Safety Lamps are designed to provide a visual warning for pedestrians moving in the vicinity of materials handling equipment. The adjustable light projects a bright red/blue/green arc of light onto the floor, indicating a clear no-go-zone, ensuring pedestrians stay a safe distance away from equipment and vehicles.

FEATURES

- LED technology with low power consumption.
- Aluminium housing with polycarbonate lens.
- Two year warranty.

SPECIFICATIONS

- 12–80 VDC.
- IP68 rated.
- Part Number: 18438460 – RED
18438461 – BLUE
18438462 – GREEN

QUALITY

Meets 2004/10/EC Directive.

Meets 2006/95/EC Directive.

Recognized per ECE R10 Regulation.

RoHs recognized.

CE recognized.

CURTIS INSTRUMENTS, (UK) LTD.
5 UPPER PRIORY STREET
NORTHAMPTON NN1 2PT, ENGLAND
TEL 44 (0) 1604-629755
FAX 44 (0) 1604-629876

HALO SAFETY LAMP

DIMENSIONS mm

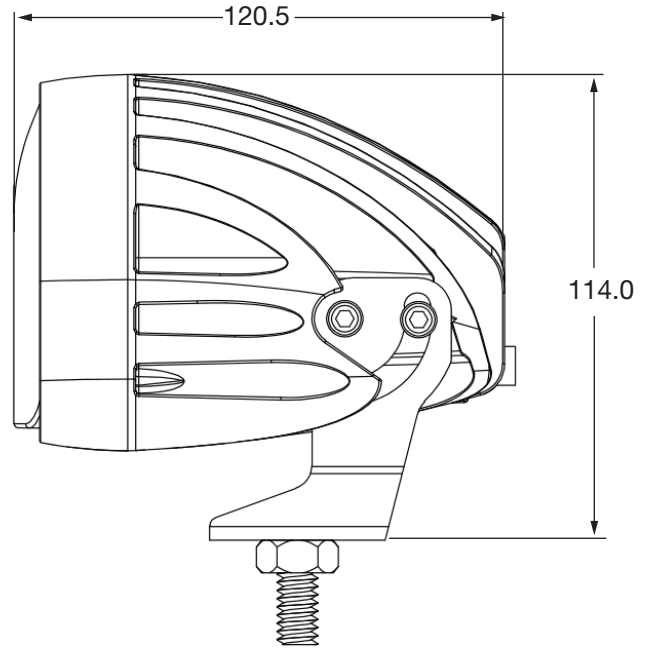
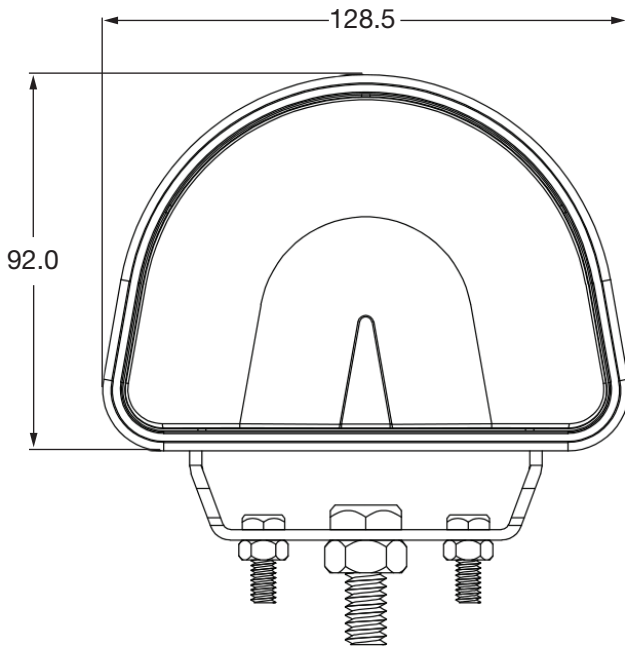

WARRANTY Two year limited warranty from time of delivery.

The Curtis Difference
You feel it when you drive it

