

## MULTI VOLTAGE LED SPOT LAMPS

### BLUE SPOT LAMP



#### FEATURES

- Very low footprint
- Bright spot beam projects a “ball of light” onto the floor, indicating an approaching vehicle
- High quality aluminium housing with impact resistant polycarbonate lens
- 250 Lumen Spot Beam
- Mounting bracket provided

#### UK PART NUMBER

18438451 - Oval Blue Spot W/Lamp

#### DESCRIPTION

A 12-80V low power draw LED Spot lamp on a single bolt fixing, with a 250 lumen output projecting a ball of coloured light onto the warehouse floor.

#### APPLICATION

These LED Spotlights provide a visual warning for pedestrians in the vicinity of materials handling equipment like Forklift Trucks. These lights project a bright, 250 lumen spot beam onto the ground, either in front or to the rear of an approaching vehicle, providing an advanced visual warning to pedestrians working nearby. This safety spot lamp is especially useful where blind corners or warehouse racking is present.

**CURTIS INSTRUMENTS, (UK) LTD.**  
5 UPPER PRIORY STREET  
NORTHAMPTON NN1 2PT, ENGLAND  
TEL 44 (0) 1604-629755  
FAX 44 (0) 1604-629876

# BLUE SPOT LAMP

## SPECIFICATIONS

- IP68 rated
- 12-80VDC
- Dimensions: 41mm x 135mm x 110mm (h, w, l)
- Weight: 500g

## DIMENSIONS mm

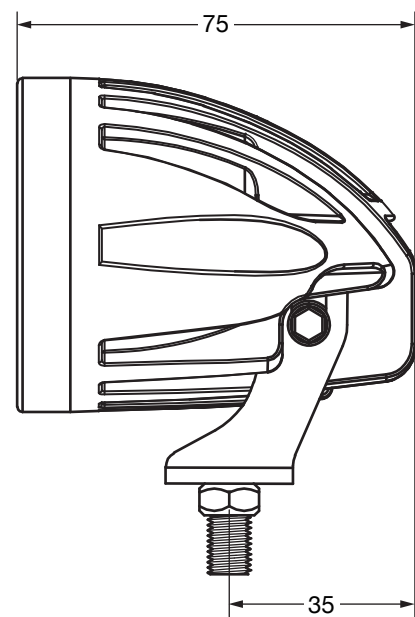
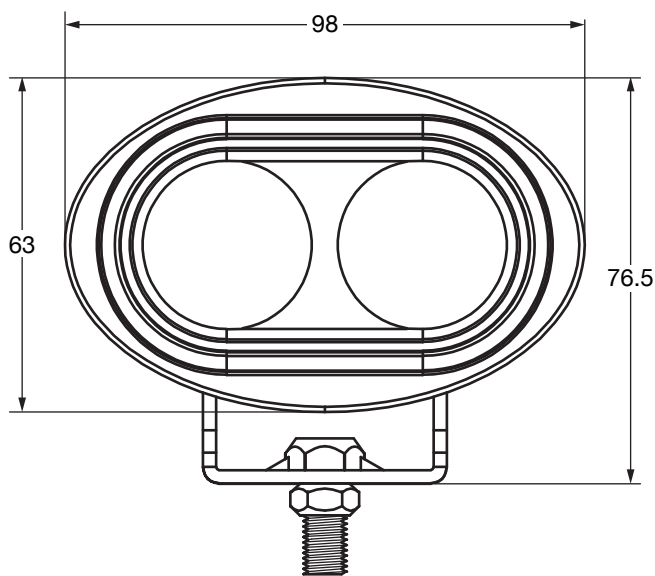

**WARRANTY** Two year limited warranty from time of delivery.

