

Solid State Battery “Fuel” Gauge

Model 909R



Model 909R

Solid State Battery "Fuel" Gauge



SPECIFICATIONS

Electrical

Operating Voltage

Signal Name	Min.	Nominal	Max.
B++ (48 V)	36 V	48 V	60 V
B+ (36 V)	27 V	36 V	45 V
Keyswitch	27 V	36/48 V	60 V

Operating Current

Signal Name	36 V Input		48 V Input	
	Typical (mA)	Max. (mA)	Typical (mA)	Max. (mA)
B++ (48 V)	N/A	N/A	17	28
B+ (36 V)	16	28	N/A	N/A
Keyswitch	375	570	270	425

USB Output

Voltage

The voltage supplied by USB port is 4.75 V to 5.25 V.

Current

The 909R will supply up to 2 A of charging current to the USB charging port at ambient temperatures up to +50°C. At temperatures above +50°C protection circuitry within the 909R will turn off the output current. The figure below depicts the maximum current that the 909R can supply to the USB charging port before the protection circuit is activated at various ambient temperatures.

USB Output Current

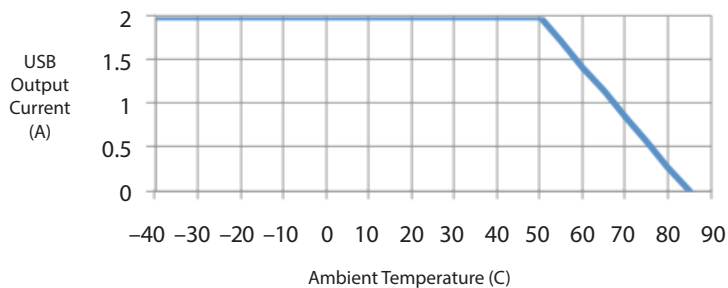

BDI profile selection

Four programmable charge/discharge profiles are available and can be selected using external pins PRG1 and PRG2:

PRG1	PRG2	Reset Profile	Discharge Profile
Open	Open	B	N
Open	B-	N	G
B-	Open	B	G
B-	B-	N	M

Discharge Profile Options

Letter Code	Volts per Cell	
	Full	Empty
G	1.97	1.75
M	2.00	1.83
N	2.04	1.73

Reset Profile Options

Letter Code	Volts per Cell		
	Open Circuit Reset	Charge Tracking Reset Full	Charge Tracking Reset Empty
B	2.090	2.35	2.10
N	1.980	2.230	2.10

Alarm

When the BSoC drops below 20 %, the buzzer turns on for 15 seconds, then off for 1 minute. At this point, the threshold for turning the buzzer off becomes 50 %, with no buzzer while charging. Once the battery is charged above 50 %, threshold returns to 20 %. The buzzer is active only when the Keyswitch is active.

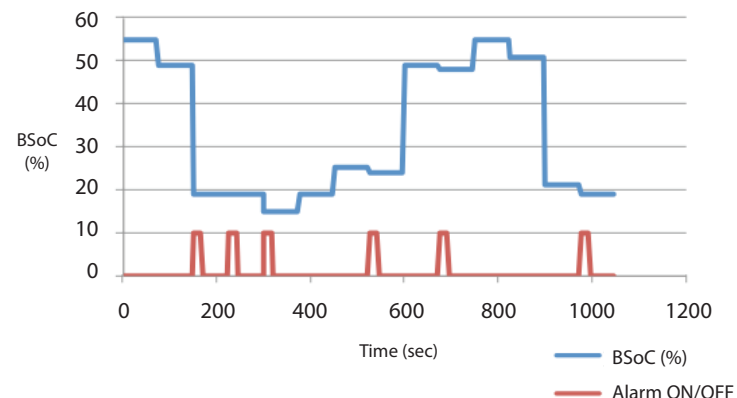

Model 909R

Solid State Battery “Fuel” Gauge

SPECIFICATIONS cont'd

Environmental

Operating Temperature:

Gage: -40° C to +85° C.

USB Charger: -40° C to +50° C with charge current derated linearly.

Storage Temperature:

-40° C to +85° C.

Humidity:

Soak: Designed to meet EN 60068-2-78.

Test Cab: Damp Heat, Steady State, 10 days at 93% RH ($\pm 3\%$), 30° C.

Cyclic: Designed to meet EN 60068-2-30.

Test Db: Damp Heat, Cyclic (12 hr + 12 hr cycle). Test method variant 1.6 cycles (each cycle is 24 hrs.), 90 % RH.

Ingress Protection:

Designed to meet EN 60529 – IP65 front, IP65 rear (with connector installed).

Shock:

Designed to meet EN 60068-2-27: 3 shocks in all 3 axes in both directions (18 shocks in total), 500 m/s², 11 ms, half sine wave.

Vibration:**General:**

Designed to meet EN 60068-2-6, Swept Sine Wave method, Section 8.2, 5g, 20 cycles in each plane, 5 to 500 Hz, 1 Octave/min. Amplitude = +/- 15 mm; Amplitude < +/- 15 mm Acceleration = 5g.

Random:

Designed to meet EN 60068-2-64. Test Fh: vibration, broadband random (digital control) and guidance. Method 1, random excitation, 5 hrs in each axis, 10 to 350 Hz.

Resonance:

Designed to meet EN 60068-2-6. Vibration sinusoidal. Section 8.1. 5g, 5 mins at resonant points, 1 Octave/min, Swept Sine Wave 10 to 2000 Hz.

EMC Specifications

Emissions (Broadband & Narrowband)

Designed to be in compliance with the requirements of UN ECE/324 Addendum 9 Regulation 10 Revision 4 (6 March 2012) for an Electrical/electronic sub-assembly (ESA) with regard to electromagnetic radiated emissions for the device under test (DUT).

Immunity

ESD: Designed to meet IEC 61000-4-2: Test level IV (8 kV contact discharge or 15 kV air discharge) according to ISO 10605:2001, Table B.1.

Radiated Immunity: Designed to meet: 30 V/m (20 MHz to 1 GHz) when tested per ISO 11452-2, Absorber-Lined Chamber (single sample).

Conducted Immunity: Designed to meet IEC 61000-4-4: Test level 4 (4 kV peak, 2.5 kHz repetition rate).

Regulatory Approvals

UL:

UL recognition to UL 583 as authorized in file AU1841 – PENDING.



Model 909R

Solid State Battery "Fuel" Gauge



WIRING DIAGRAM

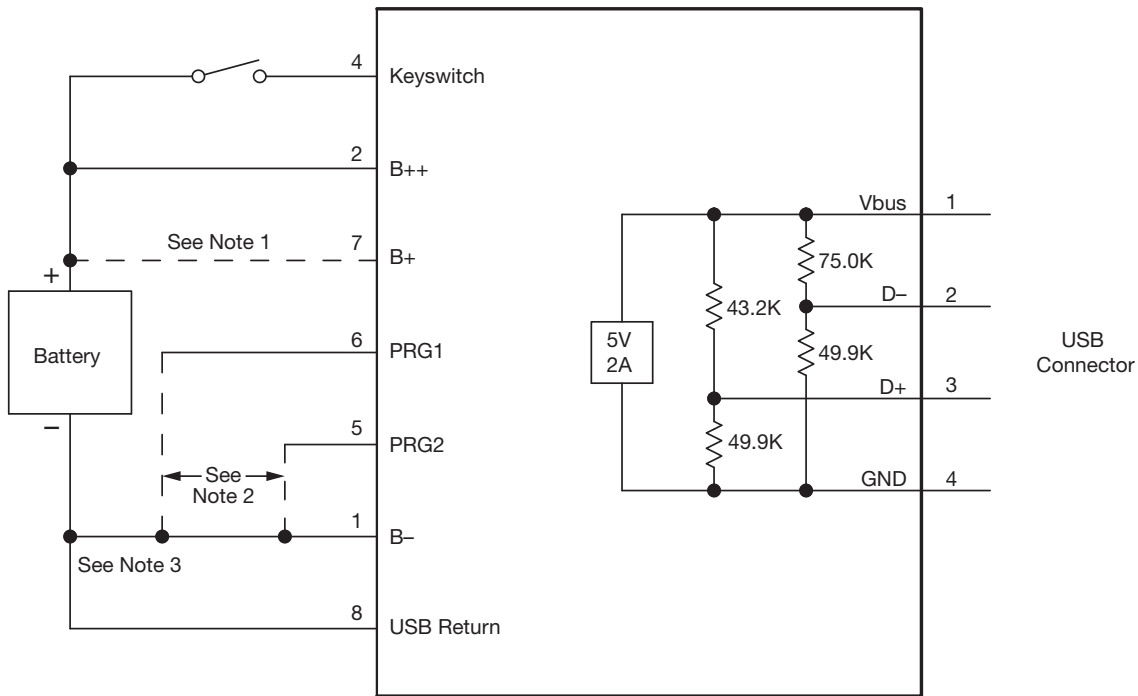

Note 1: For 48V System, connect B+ to Pin 2 (B++); for 36V System, connect B+ to Pin 7 (B+).

Note 2: Connect PRG 1 & PRG 2 for desired BDI Reset & Discharge Profile. See Manual.

Note 3: For optimal BDI accuracy, B+ (Pin 2 or 7) & B- (Pin 1) should be wired directly to the Battery Terminals and a separate wire run from USB Return (Pin 8) back to B- (Pin 1).

CONNECTOR

Pin	Signal Name	Description
PIN 1	B-	Common
PIN 2	B++	High Voltage B+
PIN 3	N.C.	—
PIN 4	Keyswitch	—
PIN 5	PRG2	BDI profile select
PIN 6	PRG1	BDI profile select
PIN 7	B+	Low Voltage B+
PIN 8	USB Return	—

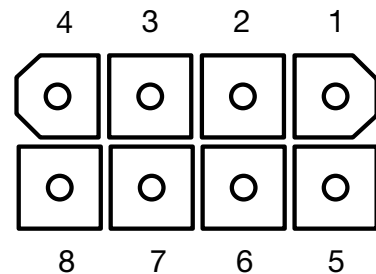

Mating Connector for J1

Part	AMP P/N
Connector Housing	794821-1
Terminal (18 – 24 AWG)	770904-X
Wire Seal	794758-1
Interface Seal	794772-8

Model 909R

Solid State Battery "Fuel" Gauge



DIMENSIONS mm

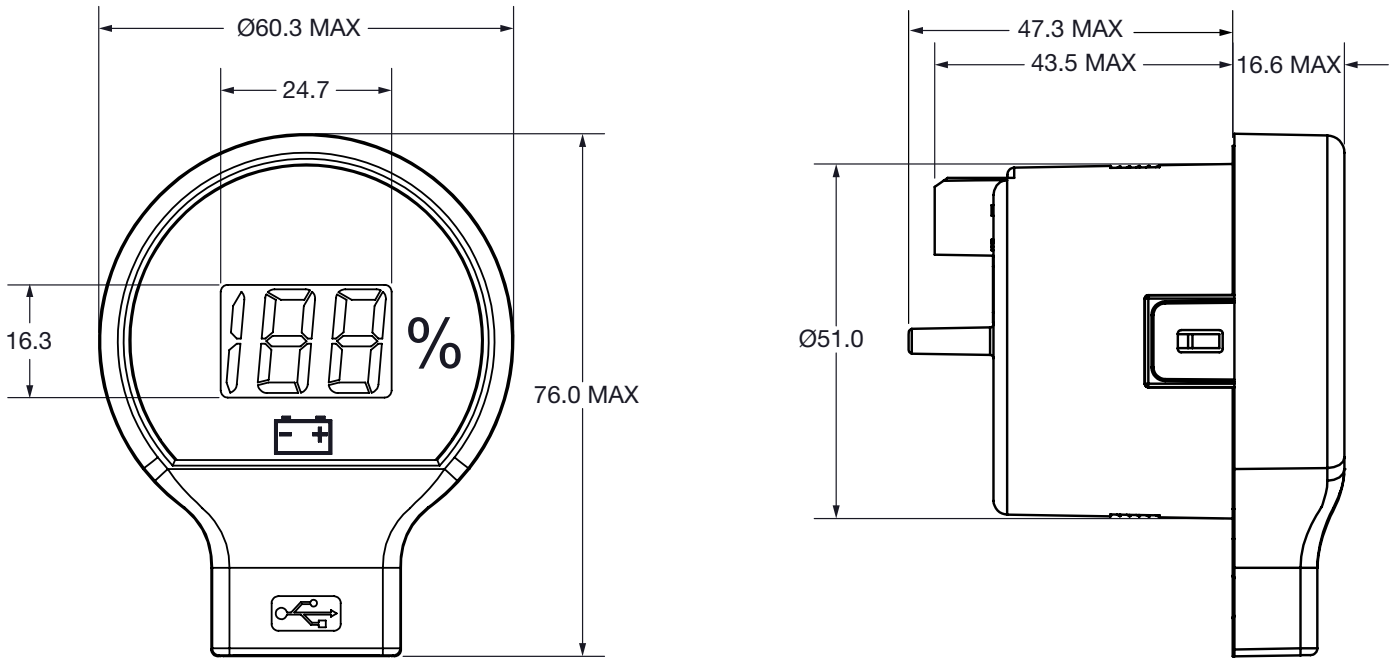

WARRANTY Two year limited warranty from time of delivery.

The Curtis Difference 
You feel it when you drive it