



CURTIS

A KOHLER COMPANY



Isolated CAN Module

Model 1360

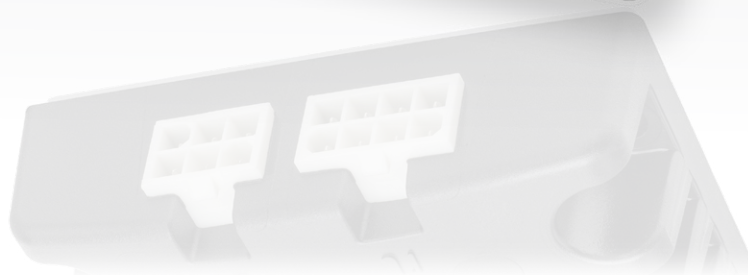

Model 1360

Isolated CAN Module



Curtis Model 1360 is an easy to implement CANbus isolation module, ideal for any CANbus application. The 1360 can be utilized to mitigate unwanted voltage or current on a bus originating from EMC, ground loops or multiple voltage source systems. It is designed to isolate one CANbus from another, effectively eliminating bus noise and errors while facilitating communication between the two busses. The module contains optionally connected 120-ohm CAN termination resistors making it easy to terminate a bus within the module.

FEATURES

- ▶ Integrates easily into a system by simply connecting two CAN buses to the module and it will effectively isolate one bus from the other.
- ▶ Hardware only design - no need to update or configure firmware.
- ▶ Includes 120 ohm CAN termination resistors allowing flexibility in system design.
- ▶ Allows for CAN shield termination effectively reducing bus noise.
- ▶ Easily operates in demanding conditions with an operational temperature range of -40° to $+85^{\circ}$ C and IP67 ingress protection.
- ▶ Supports CAN baud rates from 50kbps to 1Mbps.
- ▶ CE compliance with regard to EMC and ROHS, UL recognition and ROHS2 compliance ensure compatibility with global regulatory safety.



Model 1360

Isolated CAN Module



SPECIFICATIONS

Electrical

Voltage Ranges:

Nominal	Min.	Max.
12V – 24V	9V	30V

Operating Currents:

System Voltage	Typical (mA)	Max. (mA)
12V – 24V	82	113

Isolation Voltages:

Withstand isolation voltages up to 1500Vrms for 1 minute.

Baud Rate:

50kbps to 1Mbps

Environmental

Operating Temperature:

-40°C to +85°C.

Storage Temperature:

-40°C to +85°C.

Humidity:

Soak: EN 60068-2-78.

Test Cab: Damp Heat, Steady State, 10 days at 93% RH ($\pm 3\%$), 30°C.

Cyclic: EN 60068-2-30.

Test Db: Damp Heat, Cyclic (12hr + 12hr cycle). Test method variant 1. 6 cycles (each cycle is 24hrs), 90% RH.

Ingress Protection:

EN 60529 - IP67

Shock:

EN 60068-2-27: 3 shocks in all 3 axes in both directions (18 shocks in total), 500 m/s², 11 ms, half sine wave.

Vibration:

General:

Designed to meet EN 60068-2-6, Swept Sine Wave method, 5g, 20 cycles in each plane, 5 to 500 Hz, 1 Octave/min. ; Amplitude = +/- 15mm; Amplitude < +/- 15mm; Acceleration = 5g.

Random:

Designed to meet EN 60068-2-64. Test Fh: vibration, broadband random (digital control) and guidance. Method 1, random excitation, 5hrs in each axis, 10 to 350 Hz..

Resonance:

Designed to meet EN 60068-2-6. Vibration sinusoidal, 5g, 5 mins at resonant points, 1 Octave/min, Swept Sine Wave 10 to 2000 Hz.

EMC Specifications

Emissions (Broadband & Narrowband):

Designed to meet UN ECE/324 Addendum 9 Regulation 10 Revision 4 (6 March 2012) for an Electrical/electronic sub-assembly (ESA).

Immunity:

ESD: Designed to meet IEC 61000-4-2: Test Severity Levels for Component Test, Category 1 (8 kV contact discharge or 15 kV air discharge) according to ISO 10605:2008, Tables C.1, C.2 & C.3.

Radiated Immunity: Designed to meet: 20 V/m w/80% AM(1kHz) (27 MHz to 1 GHz); 3V/m w/80% AM(1kHz) (1 to 2GHz) & 1V/m w/80% AM(1kHz) (2 to 2.7GHz) when tested per EN 61000-4-3.

Conducted Immunity: Designed to meet IEC 61000-4-4: Test level 4 (4 kV peak, 2.5 kHz repetition rate).

Magnetic Immunity: Designed to meet: 1000A/m @ 0 Hz for 3 sec and 30A/m @ 50 Hz per EN 61000-4-8.

Regulatory Approvals

UL: UL recognition to UL 583.

CE: The product complies with the requirements of the EMC Standards and RoHS directive 2011/65/EU (RoHS 2). The product conforms to the following product specifications and regulations:

EMC:

Radiated Emissions: UN ECE/324;

Radiated Immunity: ISO 11451-1 and ISO 11451-2, using the RF levels defined in BS EN 13309:2010;

Electrical Transient Conduction: IEC 61000-4-4: Test level 4 (4 kV peak, 2.5 kHz repetition rate); ESD: ISO 10605: 2001.

RoHS: RoHS directive 2011/65/EU (RoHS 2).

Model 1360

Isolated CAN Module



DIMENSIONS mm

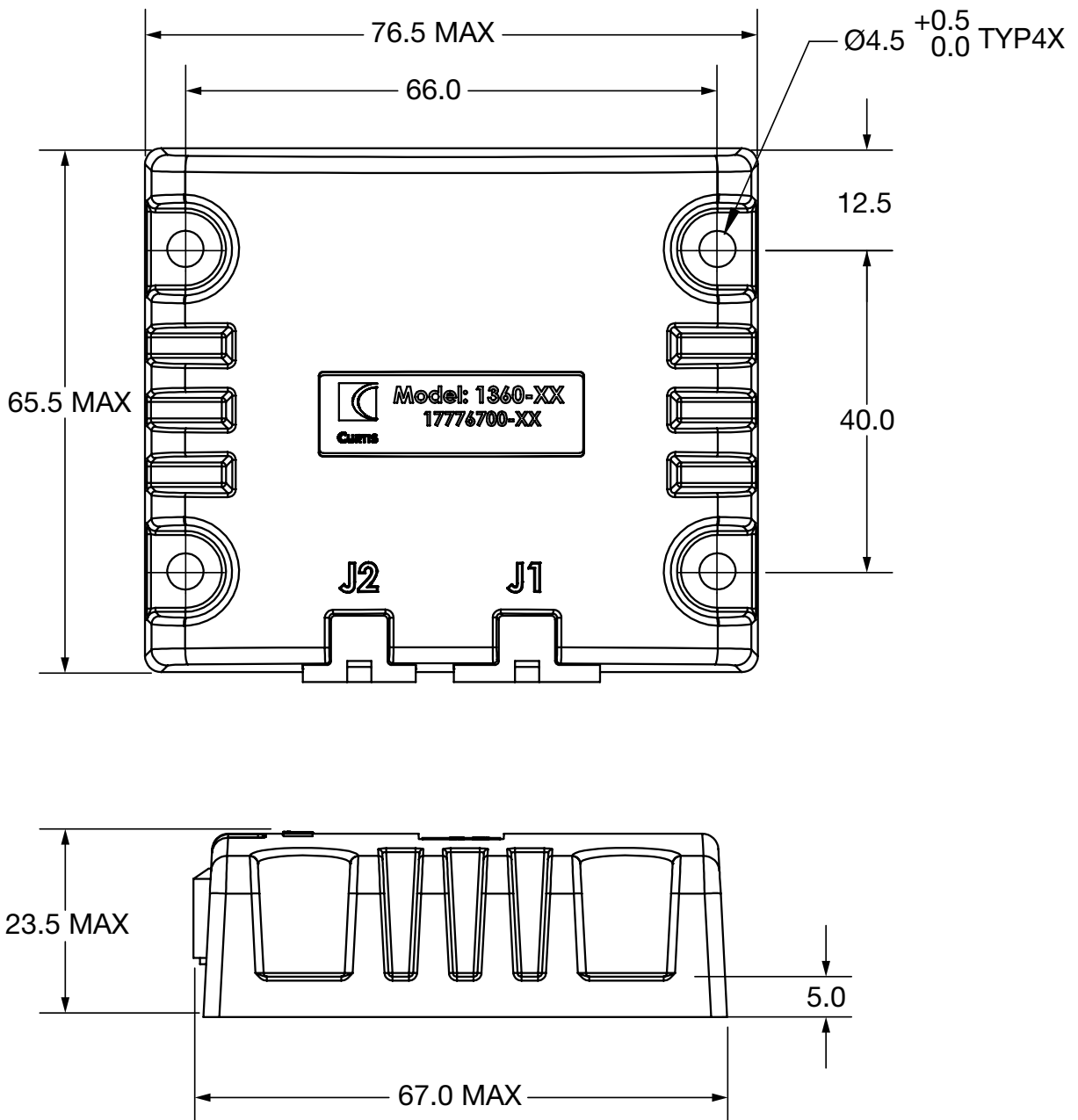

Model 1360

Isolated CAN Module



WIRING DIAGRAM

The figure below is a representative wiring diagram for model 1360.

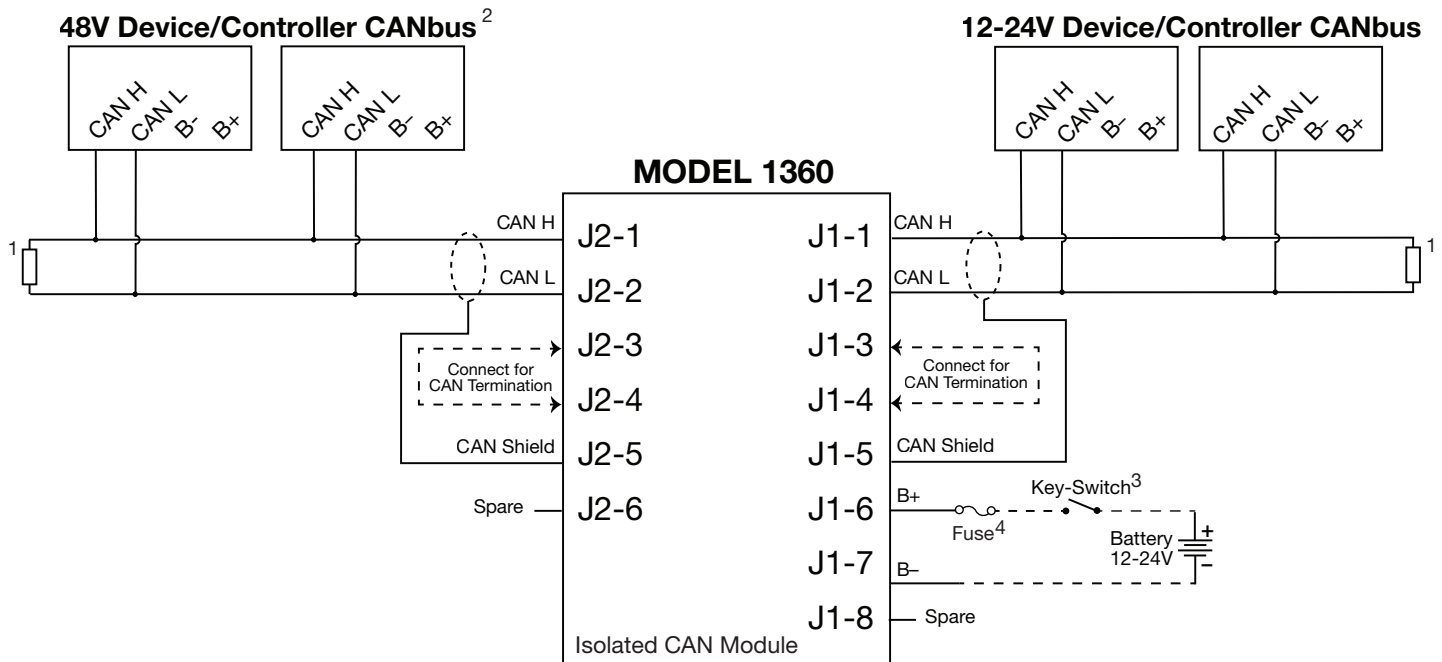

- ¹ Termination Resistor. Two termination resistors are required on each bus, one termination resistor at each end of the bus..
- ² Any CANbus system using a different voltage system (separate ground references) from the 1360 Module's 12 or 24 volt system.
- ³ System Key-Switch supplying the 1360, typically from a motor controller or vehicle controller's electrical system.
- ⁴ Fused circuit (as part of the key-switch/vehicle system).

Notes:

- The wiring diagram may not fully meet your application's requirements. For questions on how to implement your application, contact your Curtis distributor or support engineer.
- To maintain UL recognition, it is the responsibility of the installer to use a fuse rated no greater than 4A.

Model 1360

Isolated CAN Module



MODEL ENCODEMENT

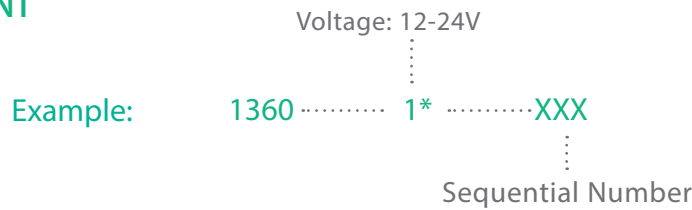

*The only voltage option for this product is 12-24, indicated by "1"

The shipping assembly numbers will be: 1776700-XXXX

CONNECTOR

The Model 1360 has two TE/AMP right angle headers, J1 which is an 8-pin header and J2 which is a 6-pin.

TE part numbers for these headers are as follows:

8-pin: 1-770970-0

6-pin: 1-770969-0

The signals are assigned as shown in the tables below.

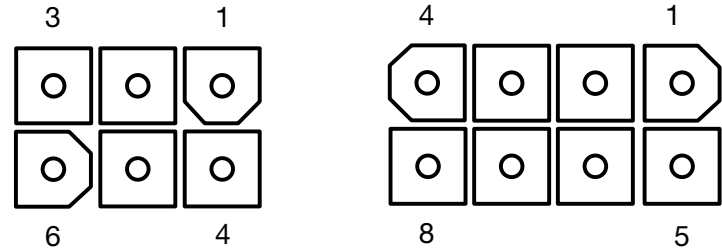

Pin	Signal Name	Description
J2-1	CAN 2 HI	
J2-2	CAN 2 Low	
J2-3	CAN 2 Term +	Connect pin J2-3 to pin J2-4 to insert 120 Ohm CAN termination.
J2-4	CAN 2 Term -	Connect pin J2-3 to pin J2-4 to insert 120 Ohm CAN termination.
J2-5	CAN 2 Shield	Termination for CAN Shield wire.
J2-6	Spare	

Pin	Signal Name	Description
J1-1	CAN 1 HI	
J1-2	CAN 1 Low	
J1-3	CAN 1 Term +	Connect pin J1-3 to pin J1-4 to insert 120 Ohm CAN termination.
J1-4	CAN 1 Term -	Connect pin J1-3 to pin J1-4 to insert 120 Ohm CAN termination.
J1-5	CAN 1 Shield	Termination for CAN Shield wire.
J1-6	B+	Input power from 12 to 24V nominal system.
J1-7	B-	Input power ground.
J1-8	Spare	

MATING CONNECTOR

The mating connectors for the Model 1360 are an 8-pin and a 6 pin TE/AMP sealed plug connector. The TE/AMP part numbers to assemble a sealed mating assembly are given in Table to the right.

Part Description	TE P/N
8 Pin Plug, Sealed Connector body	794821-1
6 Pin Plug, Sealed Connector body	794895-1
Terminal-Socket (18 – 22 AWG) strip	770904-1
Terminal-Socket (18 – 22 AWG) loose	770988-1
8 Pin - Interface Seal	794772-8
6 Pin - Interface Seal	794772-6
8 Pin Gang Wire Seal	1586359-8
6 Pin Gang Wire Seal	1586359-6
Single Wire Seal (18 – 26 AWG) *	794758-1
Unused cavity plug seal	794995-1
Crimping Tool Assembly (w/die 90759-2)	90759-1

* Wires can be sealed using either a gang wire seal or individual single wire seals

WARRANTY

Two year limited warranty from time of delivery.