

PERMANENT MAGNET MOTOR SPEED CONTROLLER

MODEL 1228

CURTIS



DESCRIPTION

Curtis PMC Model 1228 Permanent Magnet Motor Speed Controllers provide smooth and precise operating control, providing maximum user confidence. Model 1228 fully complies with European and US regulations and is fully programmable.

WARRANTY

Two Year Limited Warranty
(see terms of sale for specifics).

Application

Ideal for OEM applications on three or four wheeled mobility aids, such as scooters and for light industrial equipment such as sweepers and scrubbers.

Features

- Four quadrant, full bridge solid-state design.

Meets US and European Regulations

- Curtis Model 1228 motor speed controllers are designed to carry the CE mark in compliance with EMC directive 89/336/EEC.
- EMC and EMI per:
 - PREN 12184:1995
 - EN55011/03.91
 - EN61000-4.2:1996
 - EN61000-4.3:1997
 - EN50204:1995

- All software documentation needed to support 510K FDA filing is available.

Fully Programmable

- Easily adapted to meet many specific scooter or light industrial equipment applications.
- Seat lift function is programmable to allow a single controller to implement traction and lift functions.
- Use of an electromagnetic brake is user selectable depending upon the type of application.

Easy to Install, Set-Up and Diagnose

- Standard 18-pin Molex Mini-fit Jr. logic connectors makes wiring simple and inexpensive.
- Internally protected against damage due to possible mis-wiring during installation.
- Can be interfaced with normal or inverted, wig-wag (center off), single ended (speed pot and direction switch), and 0-5V throttle types, including limited range throttles down to 500Ω full stroke.
- Auxiliary B+ and B- terminals and an inhibit input for connecting to a battery charger.
- Diagnostic information (throttle faults, low battery, etc.) is available through dash-mounted LED flash codes and Curtis handheld programmers.

Powerful Safety Features

- Inhibit input prevents driving during charging.
- Control monitoring functions prevent driving with a defective throttle or associated wiring.
- Fault monitoring capability of electromagnetic brake functions is OEM selectable for individual vehicle requirements.
- If the keyswitch signal is turned Off while driving, the vehicle will decelerate normally, rather than stopping abruptly.
- Where electromagnetic brake is used, push input electrically releases brake for key-on pushing.
- If the vehicle is allowed to freewheel, the controller will automatically limit the maximum speed to a preset low speed.
- A user supplied external warning beeper can be installed to alert bystanders when moving in reverse direction.
- The braking current limit is not decreased with high temperature, allowing the controller to provide maximum braking on extended down-slopes.

Smooth, Secure Driving Feel

- The feel of advanced closed-loop control algorithms gives the operator confidence in the handling, operation and control of the vehicle, whether it is driving at full speed, on a steep hill or inching over a curb.

- Provides superior low speed control by compensating for both motor and controller losses.
- The motor current limit is smoothly reduced as the controller heats up beyond thermal limits, making available the maximum safe power under all conditions.
- With the electromagnetic brake selected, the controller varies the brake operation to provide smooth and secure stops.
- Provision for a separate speed limit pot allows smooth, linear adjustment of top speed.
- Gear softening compensates for slack in worn transaxles to provide smooth transitions.

Designed and Built for Optimum Reliability, Convenience and Economy

- Conservative components rating provides years of trouble-free operation, and lower warranty costs.
- Power Saver shuts the controller Off after a programmable time preserving the battery.
- MultiMode™ control allows the user to select two entirely different sets of driving parameters for different driving modes, such as indoor and outdoor use.
- Battery Discharge Indicator (BDI) driver provides battery state-of-charge on a simple, user supplied voltmeter.
- Appropriate mounting or shielding is required to prevent exposure of controller electronics when used in wet or high particulate environments. Environmental rating of controller is IP40.

Dimensions - mm (inches)

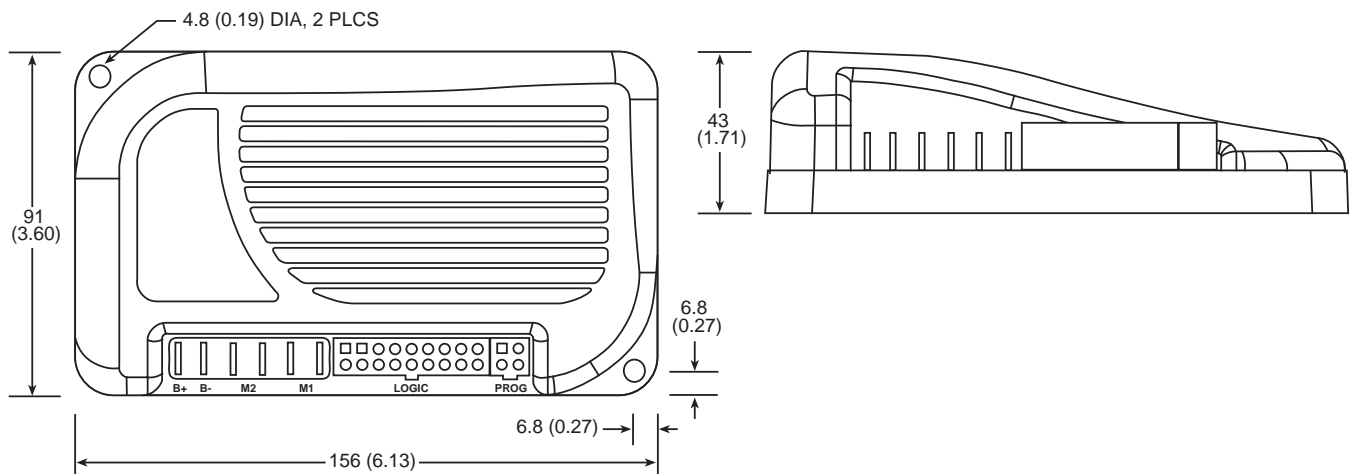

Model Chart

Model No.	Voltage Rating (volts)	Drive Current Rating			Undervoltage Cutback (volts)	Overvoltage Cutoff (volts)
		15 Sec. (amps)	1 Min.* (amps)	1 Hour* (amps)		
1228-24XX	24	70	70	35	17	36
1228-27XX	24	110	75	35	17	36

* Typical value, application dependent.

Typical Wiring

