



CURTIS

Instrumentation



# CAN and Serial Instrumentation

## Models 3140 and 3141



# Models 3140 and 3141

## CAN and Serial Instrumentation



Curtis Models 3140 and 3141 are designed to display critical vehicle and motor controller data in an easy-to-read and attractive LCD. The display includes three 10mm digits and six 5mm digits and all digits are in 16-segment format to allow the full use of the alpha numeric character set. Model 3141 adds three LED indicators below the LCD to identify critical vehicle status. Models 3140 and 3141 integrate seamlessly with Model F2-A and other CANopen-based motor controllers.

### FEATURES

- ▶ Integrates seamlessly with Curtis Model F2-A (and other CANopen-based motor controllers) thereby reducing the amount of development work by the vehicle designer.
- ▶ Attractive fixed-segment, transfective LCD with 16-segment digits and informative symbology allows intuitive reading in all lighting conditions and battery-powered vehicle environments.
- ▶ Model 3141 features 3 LED's in the instrument face which are controllable via the CANbus and can be illuminated to identify critical user-defined functionality.
- ▶ Industry standard 52mm panel cutout allows the use of existing panel/tool designs thereby lowering development cost.
- ▶ Battery State-of-Charge (BSOC) can be calculated in the 3140/1 or sent to the 3140/1 by the Model F2-A (or equivalent CAN-based motor controller).
- ▶ Models 3140/1 will run at one of seven selectable baud rates: 20kbps, 50kbps, 125 kbps, 250 kbps, 500 kbps, 800 kbps, and 1 Mbps. The baud rate can be factory programmed or changed by an SDO.
- ▶ In addition to the 3 and 6 digit portions of the LCD, a percent symbol, wrench symbol and decimal point are also present which provides more comprehensive information about vehicle status.
- ▶ Single unit operates from 24, 36 or 48 VDC allowing use on many models of battery-powered vehicles.
- ▶ Optional backlighting and LCD heater allow use in low-light and cold-store applications.
- ▶ Optional integral CAN termination resistor allows flexibility in customer vehicle design.
- ▶ Integrated 6-pin Mini-Universal MATE-N-LOCK connector allows for an easy and environmental protected connection.
- ▶ Environmentally protected (IP65 front, IP54 rear) to allow use in harsh environments.
- ▶ CE compliance, UL recognition and RoHS2 compliance ensure compatibility with global regulatory standards.



# Models 3140 and 3141

## CAN and Serial Instrumentation



### DIMENSIONS mm

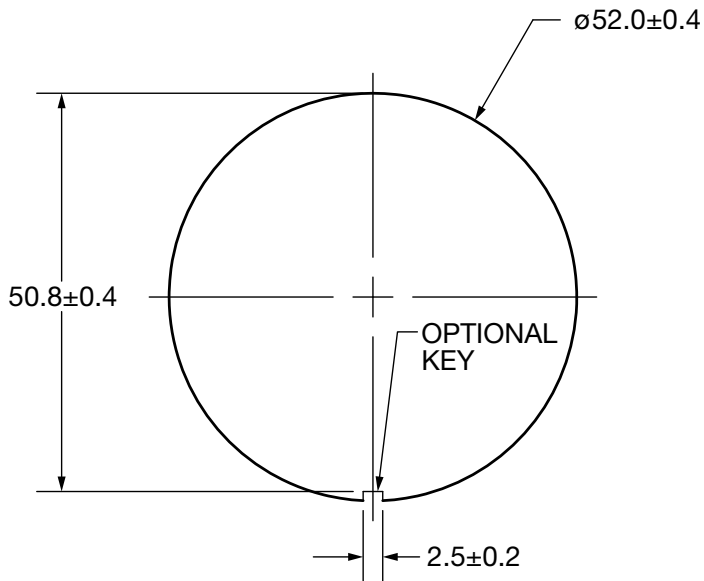
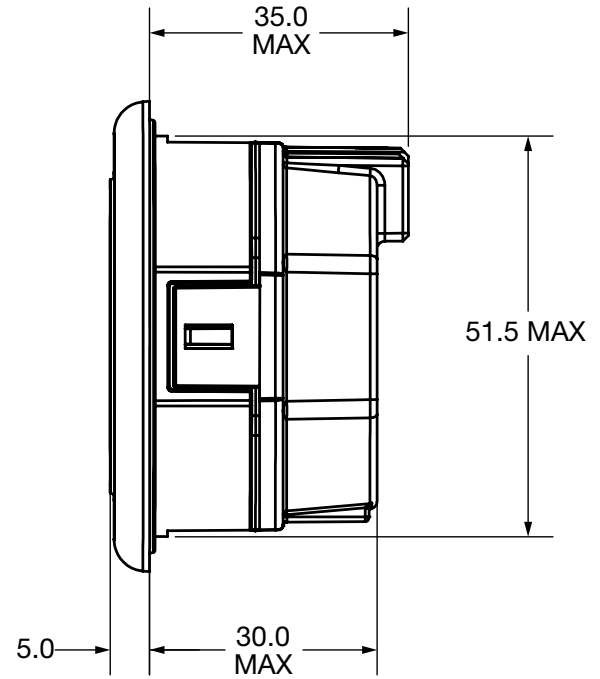
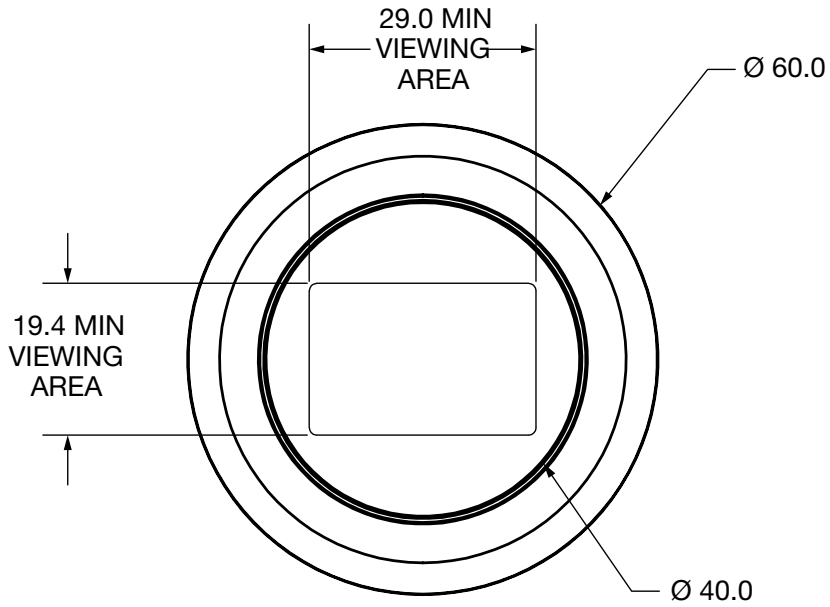

# Models 3140 and 3141

## CAN and Serial Instrumentation



### SPECIFICATIONS

#### Electrical

Models 3140 and 3141 are designed to operate over these voltage ranges:

Model	Min.	Nominal	Max.
2448	18 V	24 – 48 V	60 V
12V only	9 V	12 V	32 V

12248V operating currents:

	Non-Backlit Models		Backlit Models		LCD Heater (mA)
	Typical (mA)	Max. (mA)	Typical (mA)	Max. (mA)	
B+ (24V)	14	20	24	30	140
B+ (28V)	14	20	25	31	170
B+ (36V)	14	20	25	31	140
B+ (48V)	15	21	25	32	98
B+ (60V)	15	21	26	33	82

12V operating currents:

	Non-Backlit Models		Backlit Models		LCD Heater (mA)
	Typical (mA)	Max. (mA)	Typical (mA)	Max. (mA)	
B+ (9V)	13	20	19	25	325
B+ (12V)	14	20	22	27	400
B+ (24V)	14	20	24	30	205
B+ (32V)	15	21	26	33	150

#### Environmental

##### Operating Temperature:

–10°C to +85°C  
(with optional LCD heater: –40°C to +85°C).

##### Storage Temperature:

–40°C to +85°C.

##### Humidity:

**Soak:** Designed to meet EN 60068-2-78.

**Test Cab:** Damp Heat, Steady State, 10 days at 93% RH (±3%), 30°C.

**Cyclic:** Designed to meet EN 60068-2-30.

**Test Db:** Damp Heat, Cyclic (12hr + 12hr cycle). Test method variant 1. 6 cycles (each cycle is 24hrs), 90% RH.

##### Ingress Protection:

The 3140 is designed to meet EN 60529 – Face: IP65; Rear surface: IP54.

The 3141 is designed to meet EN 60529 – Face: IP67; Rear surface: IP67.

##### Shock:

Applicable to enclosed units only: designed to meet EN 60068-2-27: 3 shocks in all 3 axes in both directions (18 shocks in total), 500 m/s<sup>2</sup>, 11ms, half sine wave.

##### Vibration:

The following vibration specifications are applicable to enclosed units only:

##### General:

Designed to meet EN 60068-2-6, Swept Sine Wave method, 5g, 20 cycles in each plane, 5 to 500 Hz, 1 Octave/min.; Amplitude = +/- 15mm; Amplitude < +/- 15mm; Acceleration = 5g.

##### Random:

Designed to meet EN 60068-2-64. Test Fh: vibration, broadband random (digital control) and guidance. Method 1, random excitation, 5hrs in each axis, 10 to 350 Hz.

##### Resonance:

Designed to meet EN 60068-2-6. Vibration sinusoidal, 5g, 5 mins at resonant points, 1 Octave/min, Swept Sine Wave 10 to 2000 Hz.

### EMC Specifications

#### Emissions (Broadband & Narrowband)

Designed to meet UN ECE/324 Addendum 9 Regulation 10 Revision 4 (6 March 2012) for an Electrical/electronic sub-assembly (ESA).

#### Immunity

**ESD:** Designed to meet IEC 61000-4-2: Test level IV (8 kV contact discharge or 15 kV air discharge) according to ISO 10605:2001, Table B.1.

**Radiated Immunity:** Designed to meet 30 V/m (20MHz to 1 GHz) when tested per ISO 11452-2, Absorber-Lined Chamber (single sample).

**Conducted Immunity:** Designed to meet IEC 61000-4-4: Test level 4 (4 kV peak, 2.5 kHz repetition rate).

# Models 3140 and 3141

## CAN and Serial Instrumentation



### SPECIFICATIONS continued

#### Regulatory Approvals

**UL:** UL recognition to UL 583.

**CE:** The product complies with the requirements of the EMC Standards and RoHS directive 2011/65/EU (RoHS 2).  
The product conforms to the following product specifications and regulations:

**EMC:** Radiated Emissions: UN ECE/324; Radiated Immunity: ISO 11451-1 and ISO 11451-2, using the RF levels defined in BS EN 13309:2010;

Electrical Transient Conduction: IEC 61000-4-4: Test level 4 (4 kV peak, 2.5 kHz repetition rate); ESD: ISO 10605: 2001.

**RoHS:** RoHS directive 2011/65/EU (RoHS 2).

### MODEL ENCODEMENT

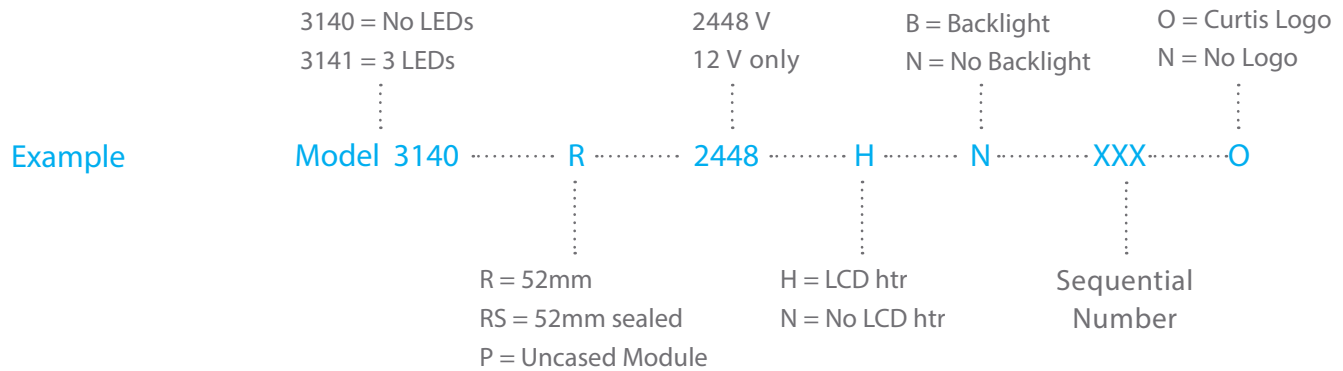

**NOTE:** Model 3140 can be specified with a factory set baud rate and/or an integral CAN termination resistor.

### CONNECTOR

Pin	Signal Name	Description
PIN 1	CAN HI	CANbus high signal
PIN 2	B+	Battery Positive
PIN 3	B-	Battery Common
PIN 4	Heater B-	LCD Heater B-
PIN 5	Heater B+	LCD Heater B+
PIN 6	CAN LO	CANbus low signal

**NOTE:** The LCD Heater B+ and LCD Heater B- pins must be tied to B+ and B-, respectively.

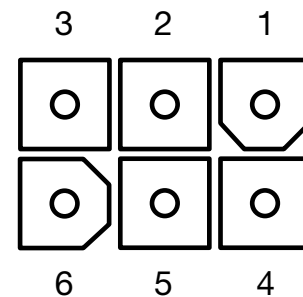

**WARRANTY** Two year limited warranty from time of delivery.



is a trademark of Curtis Instruments, Inc.

Specifications subject to change without notice

©2018 Curtis Instruments, Inc.

50302 REV E 8/18